

Appendix A

DESCRIPTION OF TEST RUNS

WAMIT V6.5 includes 23 standard test runs, including 9 low-order and 14 higher-order applications. These are designed to illustrate various different options and features of WAMIT, and to help users to develop appropriate input files for their own purposes.

The following table gives relevant features of each test run. In this table the first column *tst* denotes the name of the test run. All of the corresponding input/output files are assigned the filenames TEST*tst*. (For example, the input POT file for the first test run listed below is TEST01.POT.) The first character of *tst* is 0 for low-order test runs (ILOWHI=0), and ≥ 1 for higher-order test runs (ILOWHI=1). Test runs which are identical except for different input options are assigned the same number with a letter suffix. For example, TEST11 and TEST11a-c describe the same physical problem using different options to represent the geometry (B-splines, exact analytic formulae, MultiSurf, uniform and nonuniform mapping). In TEST14, the ISSC TLP is analysed and the use of the fixed mode option is illustrated. In TEST14a, the same geometry is analysed for a large number of input frequencies including zero and infinite frequencies and the outputs are postprocessed by the F2T utility. In TEST16 a rectangular barge is defined by the subroutine BARGE (IGDEF=-5), and in TEST16a the patches are defined by flat panels (IGDEF=0). Tests 17, 17a, and 17b illustrate alternative methods for analyzing a body with moonpools, as explained in detail in the corresponding section below. Tests 01a, 09a, 13a and 22a are examples showing the use of trimmed waterlines (ITRIMWL=1).

Several other variants of the standard test files are available separately, to licensed WAMIT users, and can be downloaded from the website www.wamit.com. These are collected into separate zip files which describe the use and implementation of special features of WAMIT, including trimmed waterlines, automatic interior free-surface representation for irregular-frequency removal, automatic control-surface representation for evaluating drift forces, and wavemakers in closed basins with and without bodies.

<i>tst</i>	geometry	ILOWHI	other parameters
	01		Circular cylinder 0
■	01a	0	Circular cylinder ITRIMWL=1
	02	0	Circular cylinder IRR=3
	03	0	Circular cylinder ISOR=1
	04	0	Barge near wall ISY=-1
	05	0	Cylinder & spheroid NBODY=2
	06	0	ISSC TLP (coarse) NPAN=128
	07	0	ISSC TLP (fine) NPAN=1012
	08	0	Elastic column NEWMDS=4
	09	0	Spar with strakes NPAND=288
■	09a	0	Spar with strakes ITRIMWL=1
	11	1	Circular cylinder IGDEF=1
	11a	1	Circular cylinder IGDEF=-1, INONUMAP=0
	11b	1	Circular cylinder IGDEF=-1, INONUMAP=1
	11c	1	Circular cylinder IGDEF=2
	12	1	Circular cylinder IGDEF=-1, INONUMAP=0, IRR=1
	13	1	Cylinder & spheroid NBODY=2
■	13a	1	Cylinder & spheroid ITRIMWL=1
	14	1	ISSC TLP IGDEF=-9
	15	1	Semi-sub IGDEF=-10
	16	1	Elastic barge IGDEF=-5
	16a	1	Elastic barge IGDEF=0
	17	1	Cylinder & moonpool IGDEF=-7,
	17a	1	Cylinder & moonpool IGDEF=-7, NEWMDS=2, IDAMP=0
	17b	1	Cylinder & moonpool IGDEF=-7, NEWMDS=2, IDAMP=1
	18	1	Elastic column IGDEF=-1, NEWMDS=4
	19	1	Catamaran barge IGDEF=0
	20	1	MultiSurf barge IGDEF=2
	21	1	Spar with strakes IGDEF=-12
	22	1	FPSO with 2 tanks IGDEF=-21
■	22a	1	FPSO with 2 tanks ITRIMWL=1
	23	1	Bank of wavemakers IGDEF=0
	24	1	Motions of a hinged vessel IGDEF=-32

All of the required input files for each test run, and the labeled output file (*.out) are included with the WAMIT software on the CD-ROM disk provided to licensed users. The same files can be downloaded with the demonstration programs from the web site <http://www.wamit.com>. The input files for Test Run *tst* are named with the filename 'test*tst*' followed by the extensions *.gdf*, *.pot*, and *.frc*. The corresponding files **fnames** and **config** are given the same filenames with the extensions **.wam** and **.cfg**. Before running TEST*tst*, the user should copy the fnames files as follows:

```
copy testtst.wam fnames.wam
```

as explained in Chapter 2. Alternatively, the batch file **runtests.bat** can be used to run

all tests in succession.

In all of the test runs metric units are used, and the gravitational acceleration is set equal to 9.80665 meters-per-second².

Each test run is described briefly in the following sections. Also included in these sections are perspective illustrations of the complete underwater geometry, including reflections about the indicated planes of symmetry, and abbreviated listings of the input files. For the low-order tests (01-09) the perspective figures show the subdivisions into panels. For the higher-order tests (11-22) two perspective figures are included, to show the subdivisions into patches (upper or left) and into panels (lower or right).

A.1 TRUNCATED VERTICAL CYLINDER – TEST01

The added-mass and damping coefficients, exciting forces, motions, wave elevations, field pressures, field velocities and drift forces are evaluated for a freely floating truncated vertical circular cylinder of radius 1 meter and draft 0.5 meters, in infinite water depth for three wave periods and one wave heading.

The origin of the coordinate system is located at the intersection of the vertical axis of the cylinder and the undisturbed position of the free surface. Using two planes of symmetry, only the first quadrant of the surface of the cylinder is discretized with 256 panels. 16, 8, and 8 panels are distributed in the azimuthal, radial, and vertical directions with equal spacing. The characteristic length is set equal to the radius of the cylinder. The cylinder center of gravity is located at the origin of the coordinate system, and the radii of gyration relative to its axes are taken equal to 1 meter.

- In TEST01A, the option to trim the waterline is specified with the parameters ITRIMWL and XTRIM included in the TEST01A.CFG file. The other input files are unchanged, but the filenames TEST01A.POT and TEST01A.FRC are used so that the output files will be named accordingly. The cylinder is rotated 15 degrees about the x -axis and elevated 0.27m, as shown in the lower figure below. The vertical elevation is required in this case since the gdf file only extends up to the original waterplane, and trimming in roll or pitch about the center without vertical displacement would submerge half of the waterline with a gap above it.

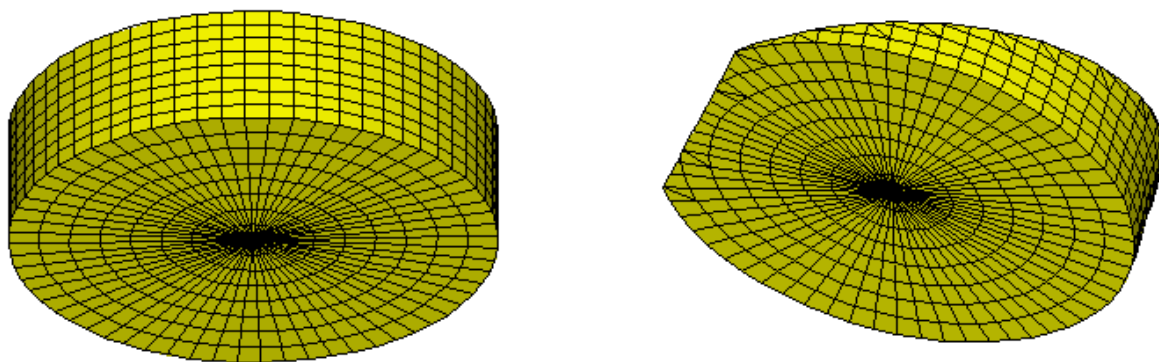

TEST01.GDF: (lines 1-8 only):

```
TEST01.GDF -- circular cylinder, R=1, T=0.5, ILOWHI=0
  1.000000      9.806650      ULEN, GRAV
      1          1          ISX, ISY
      256          NEQN
  0.0000000E+00  0.0000000E+00 -0.5000000
  0.0000000E+00  0.0000000E+00 -0.5000000
  0.1243981      1.2252143E-02 -0.5000000
  0.1250000      0.0000000E+00 -0.5000000
```

TEST01.POT:

```
TEST01.POT -- cylinder R=1, T=0.5, ILOWHI=0, IRR=0
-1. 0. 0. 0. 0.          HBOT, XBODY(1-4)
  1          1          IRAD, IDIFF
  1  1  1  1  1  1          IMODE(1-6)
  3          NPER (array PER follows)
  8.971402  2.006403  1.003033
  1          NBETA (array BETA follows)
  0.
```

TEST01.FRC:

```
TEST01.FRC Circular cylinder, ILOWHI=0, IRR=0
  1  1  1  1  0  1  1  2  0  IOPTN(1-9)
  0.000000          VCG
  1.000000          .0000000          .0000000
  .0000000          1.000000          .0000000
  .0000000          .0000000          1.000000          XPRDCT
  0          NBETAH
  2          NFIELD
  1.5  0.  0.
  1.5  0. -0.5          (end of file)
```

test01.cfg:

```
maxscr=1024 (assign a maximum block of 1024*1024 RAM for scratch LHS)
ISOR=1 (omit ISOR in POT file, include source formulation)
ISOLVE=0 (use iterative solver)
ISCATT=0 (solve for total diffraction potential, not scattering)
IQUAD=0 (omit IQUAD in POT file, use single-node quadrature)
ILOG=1 (omit ILOG in POT file, integrate log singularity)
IDIAG=0 (omit IDIAG in POT file, panel length based on area)
IRR=0 (omit IRR in POT file, no irregular-frequency removal)
MONITR=0 (do not write FORCE output data to monitor)
NUMHDR=1 (write headers to numeric output files)
USERID_PATH=\WAMITv6 (directory for *.exe, *.dll, and userid.wam)
```

```
test01a.cfg:
maxscr=1024 (assign a maximum block of 1024*1024 RAM for scratch LHS)
ISOR=1      (omit ISOR in POT file, include source formulation)
ISOLVE=0    (use iterative solver)
ISCATT=0    (solve for total diffraction potential, not scattering)
IQUAD=0     (omit IQUAD in POT file, use single-node quadrature)
ILOG=1      (omit ILOG in POT file, integrate log singularity)
IDIAG=0     (omit IDIAG in POT file, panel length based on area)
IRR=0       (omit IRR in POT file, no irregular-frequency removal)
MONITR=0    (do not write FORCE output data to monitor)
NUMHDR=1    (write headers to numeric output files)
USERID_PATH=\WAMITv6 (directory for *.exe, *.dll, and userid.wam)
ITRIMWL=1
XTRIM= 0.27 0.0 15.
```

A.2 IRREGULAR-FREQUENCY REMOVAL – TEST02

This test run illustrates the use of the irregular-frequency option described in Chapter 9. The geometry and most other inputs are the same as in TEST01, as described above. The parameter $IRR=3$ is set to use automatic panelization of the interior free surface. Wave periods are chosen so that the wave frequencies are near the first and second irregular frequencies of the cylinder.

The maximum number of iteration $MAXITT$ is increased to 100 in the configuration file for this test run.

Input GDF is the same as $TEST01.GDF$. The following figure shows additional panels on the free surface which are generated in $WAMIT$.

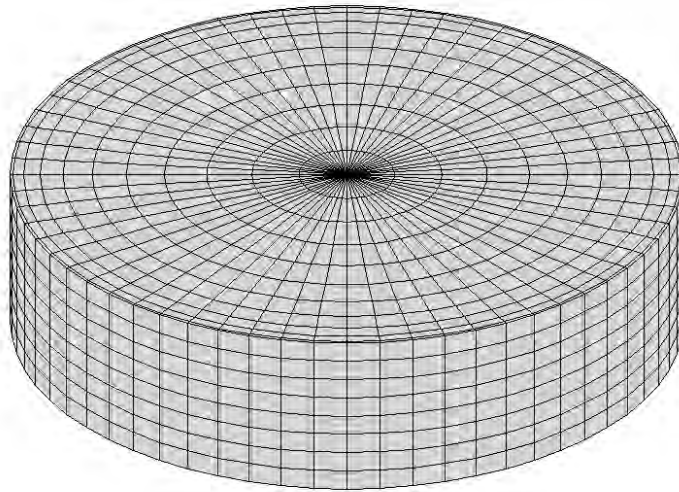

TEST02.GDF: (lines 1-8 only):

```
TEST02.GDF circular cylinder, R=1, T=0.5, ILOWHI=0, IRR=3,
  1.000000      9.806650
      1          1
      256
  0.0000000E+00  0.0000000E+00 -0.5000000
  0.0000000E+00  0.0000000E+00 -0.5000000
  0.1243981      1.2252143E-02 -0.5000000
  0.1250000      0.0000000E+00 -0.5000000
```

TEST02.POT:

```
TEST02.POT -- Circular cylinder, ILOWHI=0, IRR=3
-1.  0.0  0.0  0.0  0.0
  1          1
  1  1  1  1  1  1
  2
  1.182288    1.003025
  1
  0.0
```

TEST02.FRC:

```
TEST02.FRC -- Circular cylinder, ILOWHI=0, IRR=3
  1  1  1  1  0  1  1  1  1
  0.000000
  1.000000      .0000000      .0000000
  .0000000      1.000000      .0000000
  .0000000      .0000000      1.000000
  0
  2
  1.5 0.0  0.0
  1.5 0.0 -0.5
```

test02.cfg:

```
IRR=3
ISOR=1
ISOLVE=1
IQUAD=0
ILOG=1
IDIAG=0
NEWMDS=0
MONITR=0
NUMHDR=1
maxscr=1024
USERID_PATH=\WAMITv6 (directory for *.exe, *.dll, and userid.wam)
```

A.3 LOCAL PRESSURE DRIFT FORCE – TEST03

This test run is used to illustrate the use of the source formulation (Section 5.2) to determine the mean drift force and moment from local pressure integration. The motions and the drift forces are evaluated for a freely floating truncated vertical circular cylinder of radius 1 meter and draft 1 meter, in a water depth of 7.14 meter for four wave periods and one wave heading.

The origin of the global coordinate system is located at the intersection of the vertical axis of the cylinder and the undisturbed position of the free surface. The origin of the body fixed coordinate system is shifted -0.515 meters under the free-surface. Using two planes of symmetry, the first quadrant of the surface of the cylinder is discretized with 288 panels. 12, 8, and 16 panels are distributed in the azimuthal, radial, and vertical directions with cosine spacing at the free surface and corner. The characteristic length is set equal to the radius of the cylinder. The cylinder center of gravity is located at the origin of the body coordinate system, and the radii of gyration relative to its axes are shown in the FRC file.

Generally speaking, the evaluation of mean drift forces is more accurate when the momentum conservation method is used, since this does not depend on local velocities on the body surface. However the momentum method cannot be used to evaluate the vertical component of the drift force. Tests with larger number of panels are reported in Reference [12] to show the sensitivity of the results to the discretization of the body. The vertical drift force predicted by the mean pressure integration shows slow convergence near the heave resonance frequency ($KL=0.66$), due to cancelation between two large contributions of opposite signs (the second integration in equations (12.47) and (12.48)), when the heave motion amplitude is large.

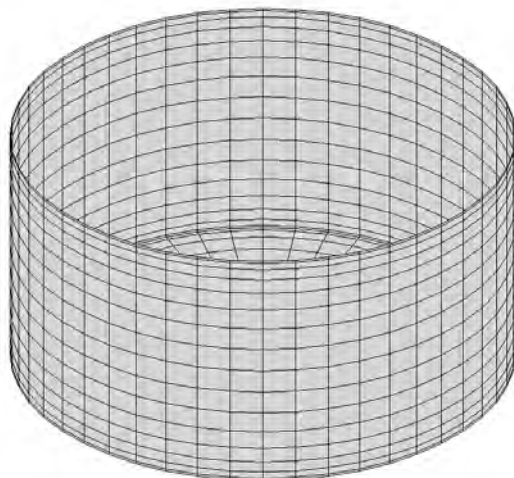

TEST03.GDF: (lines 1-8 only):

TEST03.GDF Cylinder, R=T=1, ILOWHI=0, ISOR=1

```
1.000000      9.806650
      1          1
      288
0.000000E+00  0.000000E+00 -0.4850000
0.000000E+00  0.000000E+00 -0.4850000
0.1934213     2.5464399E-02 -0.4850000
0.1950903     0.000000E+00 -0.4850000
```

TEST03.POT:

TEST03.POT Cylinder, R=T=1, ILOWHI=0, ISOR=1

```
7.14  0.0  0.0  -0.515  0.0
      1          1
      1  1  1  1  1  1
      4
2.837491  2.398118  2.006409  1.638226
      1
      0.0
```

TEST03.FRC:

TEST03.FRC Cylinder, R=T=1, ILOWHI=0, ISOR=1

```
0  0  0  1  0  0  0  1  1
0.000000
0.742000      0.000000      0.000000
0.000000      0.742000      0.000000
0.000000      0.000000      1.000000
0
0
```

test03.cfg:

```
maxscr=1024
ISOR=1
ISOLVE=0
ISCATT=0
IQUAD=0
ILOG=0
IDIAG=0
IRR=0
MONITR=0
NUMHDR=1
USERID_PATH=\WAMITv6 (directory for *.exe, *.dll, and userid.wam)
```

A.4 BODY NEAR A WALL – TEST04

The option to analyze a body near one or two vertical walls is described in Section 5.3. In this test run a rectangular barge of length 80m, beam 20m, draft 10m is positioned with its longitudinal axis parallel to one wall, separated by a gap of 2m. Incident head waves are considered, and computations are made of the surge, heave, and pitch coefficients, RAO's, and drift force and moment in incident waves which propagate parallel to the wall (BETA=0).

In the GDF file one half of the barge is discretized, forward of the midship section $x = 0$. Both the port and starboard sides of the barge are included in the GDF file, hence the appropriate symmetry indices for this case are ISX=1, ISY=-1.

Since the incident waves propagate parallel to the wall this problem is identical to the 'barge catamaran' studied in [6], and in TEST19; the only modifications required in the latter case are (1) a lateral offset equal to the sum of the half-beam and gap must be added to the y -coordinates of the panels in the GDF file; (2) ISY=1; and (3) the forces and moments calculated for the catamaran are the total acting on both hulls. The definition of the incident-wave amplitude differs between these different problems, however, due to the convention for the wave amplitude in the presence of a wall (Section 5.3). In the present case, where the incident-wave angle is zero and the waves propagate parallel to the wall, the wave system in the absence of the body is a progressive wave with total physical amplitude $2A$.

It also is possible to replicate the present results with the NBODY option, specifying two independent hulls in place of the rigid constraint implied by the catamaran; this is a less efficient computational approach since the planes of symmetry are not exploited.

The figure below shows the catamaran configuration or, equivalently, the original hull plus its image with respect to the wall.

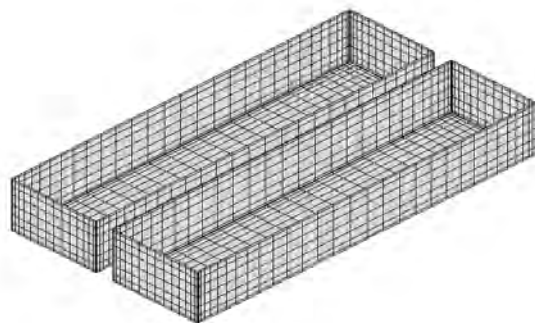

```

TEST04.GDF: (lines 1-8 only):
TEST04.GDF -- Barge near wall, ILOWHI=0
  40.00000      9.806650
      1          -1
      640
  3.920686      10.00000      -0.3806022
  0.0000000E+00  10.00000      -0.3806022
  0.0000000E+00  10.00000      0.0000000E+00
  3.920686      10.00000      0.0000000E+00

```

```

TEST04.POT:
TEST04.POT -- Barge near wall, ILOWHI=0
-1. 0. 12. 0. 0.
0      0
1 0 1 0 1 0
3
6. 7. 8.
1
0.0

```

```

TEST04.FRC:
TEST04.FRC -- Barge near wall, ILOWHI=0
1 1 1 1 0 0 0 0 1
3.0
20.00000      0.000000      0.000000
0.000000      5.000000      0.000000
0.000000      0.000000      20.00000
0
0

```

```

test04.cfg:
maxscr=1024
ISOR=1
ISOLVE=0
ISCATT=0
IQUAD=0
ILOG=0
IDIAG=0
IRR=0
MONITR=0
NUMHDR=1
USERID_PATH=\WAMITv6 (directory for *.exe, *.dll, and userid.wam)

```

A.5 MULTIPLE BODIES – TEST05

The NBODY option described in Chapter 7 is illustrated in this test run. Body one is a circular cylinder of radius 1 meter and draft 2 meters. Body 2 is a spheroid of length 4 meters and maximum radius 0.25 meters. The gap between these two bodies is set equal to the beam of the spheroid (0.5 meters) and the origin of the global coordinate system is located at the mid-point of this gap. The relative locations of the two bodies and the orientation of the spheroid are specified in the GGDF file. One quadrant of the cylinder is discretized with 112 panels. 8,6 and 8 panels are distributed in the azimuthal, radial, and vertical directions using cosine spacing in radial and vertical directions. One quadrant of the spheroid is discretized with 64 panels. 8 and 8 panels are distributed in the longitudinal, and transverse directions using cosine spacing in the longitudinal direction.

The Alternative 1 input format is used for the POTEN subprogram and the Alternative 3 input format is used for FORCE. The separate FRC files TEST05C, TEST05S are used with IALTFRC=3. The vector IALTFRCN is included in TEST05.CFG to indicate that IALTFRC=1 in the separate FRC files for each body.

The added-mass and damping coefficients, exciting forces, motions, wave elevations, field pressures and field velocities, and drift forces are evaluated in infinite water depth for two wave periods and one wave heading.

The option is used to evaluate the mean drift force and moment using a control surface, following the instructions in Chapter 14. The parameter ICTRSURF=1 is assigned in the CFG file. The control surfaces surrounding the cylinder and spheroid are defined by the input files TEST05c.csf and TEST05s.csf. In order to illustrate the alternatives, the control surface for the cylinder uses low-order panels (ILOWHICSF=0) and the control surface for the spheroid is generated with the higher-order (ILOWHICSF=1) subroutine ELLIPSOID_CS in the GEOMXACT DLL library. The corresponding output for the mean drift force and moment is contained in the file TEST05.9c. It should be noted that the higher-order control surface for the spheroid does not include the intermediate free surface patch, and thus the horizontal drift force is correct whereas the vertical drift force is not complete. The reason for omitting the free surface patch here is that the low-order solution for the body does not give a sufficiently robust evaluation of field velocities and wave elevations at points on the free surface that are very close to the body. The low-order control surface is more suitable for use with low-order body representations, in this respect, provided the panels on the free surface have dimensions similar to the dimensions of the adjacent panels on the body.

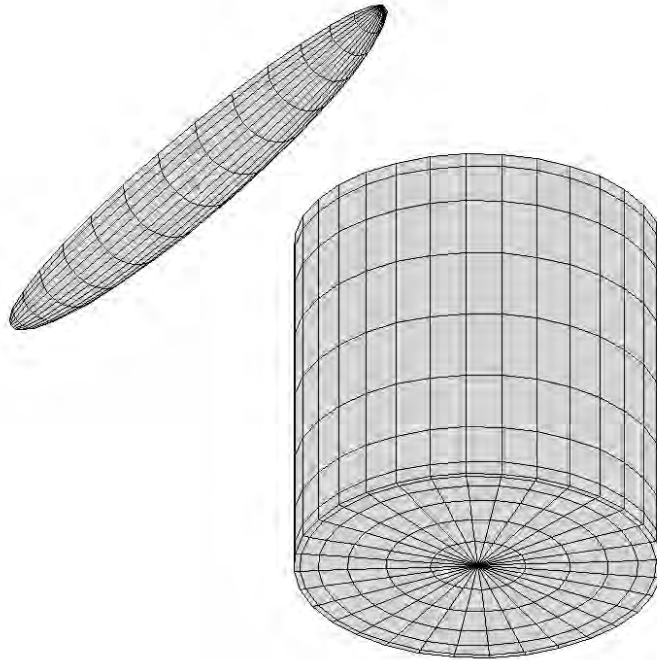

```

TEST05.GDF:
TEST05.GDF -- GGDF file for use with IGDFPOT_OPTIONS=0
-1. 9.80665
2
test05c.gdf
1.25 0.0 0.0 0.0
1 1 1 1 1 1
test05s.gdf
-0.5 0.0 0.0 90.0
1 1 1 1 1 1

```

```

TEST05c.GDF: (lines 1-8 only):
Cylinder R=1 T=2 8*(6+8)
    1.000000      9.806650
        1          1
    112
0.0000000E+00  0.0000000E+00  -2.000000
0.0000000E+00  0.0000000E+00  -2.000000
0.2538459      5.0493091E-02  -2.000000
0.2588190      0.0000000E+00  -2.000000

```

```

TEST05s.GDF: (lines 1-8 only):

```

Spheroid, Slenderness =0.125 Halflength=2m 8*8
 2.000000 9.806650
 1 1
 64
 2.000000 -0.0000000E+00 -0.0000000E+00
 1.961571 -7.9460625E-09 -4.8772585E-02
 1.961571 9.5150545E-03 -4.7835436E-02
 2.000000 0.0000000E+00 -0.0000000E+00

TEST05.POT:
 TEST05.POT -- Cylinder + spheroid, ILOWHI=0
 -1.0 0.0 0.0 0.0 0.0
 0 0
 0 0 0 0 0 0
 2
 1.5 2.0
 1
 0.0

TEST05.FRC:
 TEST05.FRC -- Cylinder + spheroid, ILOWHI=0
 1 1 1 1 0 1 1 1 1
 1.0
 test05c.frc
 test05s.frc
 0
 1
 0. 0. 0.

TEST05c.FRC:
 CYL.FRC
 0 0 0 0 0 0 0 0 0
 0.000000
 1.000000 .0000000 .0000000
 .0000000 1.000000 .0000000
 .0000000 .0000000 1.000000
 0
 0

TEST05s.FRC:
 SPD.FRC
 0 0 0 0 0 0 0 0 0
 0.000000
 1.000000 .0000000 .0000000

```
.0000000    1.000000    .0000000
.0000000    .0000000    1.000000
0
0
```

TEST05c.csf:

ccylinder R=1.2 T=2.2 -- analytic CONTROL SURFACE (npatch=3)

```
0      ILOWHICSF
1      1  ISX ISY
160    NPAN
0.12000E+01  0.00000E+00  0.00000E+00
0.12000E+01  0.00000E+00 -0.27500E+00
0.11769E+01  0.23411E+00 -0.27500E+00
0.11769E+01  0.23411E+00  0.00000E+00
```

TEST05s.csf:

ELLIPSOID CONTROL SURFACE for ellipsoid GDF-- igdef=-1003 without free surface portion

```
1  ILOWHICSF
1  1      ISX ISY
1  -1003  0.5 NPATCH  IGDEF PSZCSF
2      NLines
2.2 0.3 0.3      A, B, C
2.0 0.25 (x and y maximum of ellipsoid GDF)
```

test05.cfg:

```
IPLTDAT=1
maxscr=1024
ISOR=0
IQUAD=0
ILOG=0
IDIAG=0
IRR=0
NUMHDR=1
NOOUT=0 1 1 1 0 1 1 0 0
IALTPOT = 1      ! GDF names in GGDF file
IALTFRC = 3      ! Alternative Form 3 FRC
IALTFRCN= 1 1
ICTRSURF=1      ! Evaluate control surface drift forces
USERID_PATH=\WAMITv6 (directory for *.exe, *.dll, and userid.wam)
```

A.6 THE ISSC TENSION-LEG PLATFORM – TEST06

The added-mass, damping coefficients, exciting forces, motions and wave loads are evaluated for the ISSC Tension-Leg-Platform, in a finite water depth of 450 meters, for three wave periods and one wave heading. The TLP consists of four circular cylindrical columns and four rectangular pontoons as shown in the plots of the panel discretization. The radius of each column is 8.435 meters. The width and height of each pontoon are 7.5 meters and 10.5 meters, respectively. The distance between the centers of adjacent columns is 86.25 meters. Further information is given by Eatock Taylor and Jefferys [7].

Two planes of symmetry are used with 128 panels in one quadrant. Thus there are a total of 512 panels on the complete surface. The origin of the coordinate system is located at the intersection of the undisturbed free surface and the two planes of symmetry. The characteristic length is set equal to 43.125 meters, which corresponds to half of the distance between the centers of adjacent columns.

Only head seas are considered, with $\beta = 0$ specified in the .pot file. For this reason, only the modes (surge, heave, pitch) are analyzed with $\text{IRAD}=\text{IDIFF}=0$, and these modes are specified on line 3. There is a warning message for options 5-9, as explained in Section 10.1, since $\text{IDIFF}=0$.

In the .frc file the horizontal modes (1,2,6) are free and the vertical modes (3,4,5) are fixed, to represent a TLP moored by vertical tendons. The Alternative 1 form is used, with the result that the body mass is evaluated as if the TLP is freely floating (see Section 3.5).

The output shows the conventional response amplitude operator for surge, and the wave loads for heave and pitch.

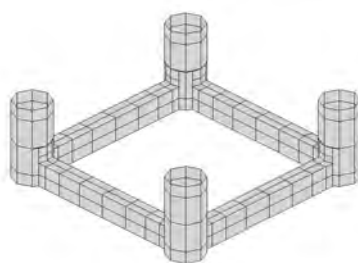

TEST06.GDF: (lines 1-8 only):

TEST06.GDF -- ISSC TLP, coarse discretization

```
43.125      9.80665
  1          1
          128
          49.09267      37.15733      0.00000
          49.09267      37.15733      -5.12567
          51.56456      43.12500      -5.12567
          51.56456      43.12500      0.00000
```

TEST06.POT:

TEST06.POT -- ISSC TLP, coarse discretization

```
450. 0. 0. 0. 0.
0 0
1 0 1 0 1 0
3
5. 10. 15.
1
0.
```

TEST06.FRC:

TEST06.FRC -- ISSC TLP, coarse discretization

```
1 1 1 -1 1 0 0 0 0 IOPTN (IOPTN(4)<0 signifies fixed modes)
6 NDFR
1 1 0 0 0 1 IMODE
3.0 VCG
38.876 0. 0.
0. 38.876 0.
0. 0. 42.420
0 NBETAH
0 NFIELD
```

test06.cfg:

```
maxscr=1024
ISOR=0
ISOLVE=0
ISCATT=0
IQUAD=0
ILOG=0
IDIAG=0
IRR=0
MONITR=0
NUMHDR=1
NOOUT= 1 1 1 1 0 1 1 1 1
USERID_PATH=\WAMITv6 (directory for *.exe, *.dll, and userid.wam)
```

A.7 THE ISSC TENSION-LEG PLATFORM – TEST07

This test run is intended to refine the analysis of the ISSC TLP described in TEST06. 1012 panels are used on each quadrant, resulting in 4048 panels for the complete structure. The block iterative solver is used (ISOLVE=4) to provide a relatively fast but robust solution. For the sake of variety in the analysis of the diffraction problem, the solution for the scattered potential is computed (ISCATT=1).

Alternative form 2 of .FRC is used, but the mass is assumed to be equal to the displacement computed by WAMIT. Note that the displacement is about 4% greater than for Test Run 2, due to the more accurate description of the columns. (The panel vertices are defined to lie on the exact circular cylinder surface, hence the flat panels define a surface with less displaced volume than the exact body.)

Comparisons should be made with the output files from TEST06 to judge the convergence of the results with increasing numbers of panels. As explained in Appendix A.6 a warning message is displayed for Options 8 and 9 since IDIFF=0.

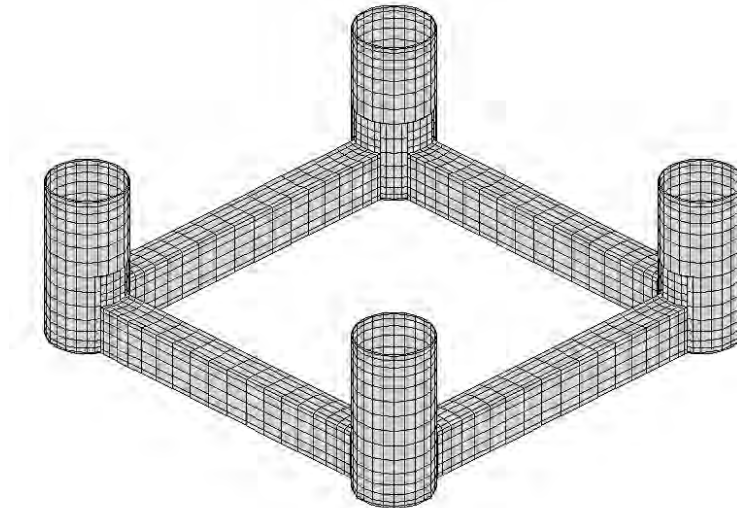

TEST07.GDF: (lines 1-8 only):

TEST07.GDF ISSC TLP -- ILOWHI=0, fine discretization

```
43.125 9.806650
1 1
1012
49.09267 37.15733 0.00000
49.09267 37.15733 -0.33626
50.43388 38.90522 -0.33626
50.43388 38.90522 0.00000
```

TEST07.POT:

TEST07.POT ISSC TLP -- ILOWHI=0, fine discretization

```
450. 0. 0. 0. 0.
0 0
1 0 1 0 1 0
3
5. 10. 15.
1
0.
```

TEST07.FRC:

TEST07.FRC ISSC TLP -- ILOWHI=0, fine discretization -- IALTFRC=2

```
1 1 1 -2 0 0 0 0 0 IOPTN (IOPTN(4)<0 signifies fixed modes)
6 NDFR
1 1 0 0 0 1 IMODE
1. RHO
0. 0. 3.0 XCG
1 IMASS
53066.4 0. 0. 0. 159199.2 0.
0. 53066.4 0. -159199.2 0. 0.
0. 0. 53066.4 0. 0. 0.
0. -159199.2 0. 8.0201552E7 0. 0.
159199.2 0. 0. 0. 8.0201552E7 0.
0. 0. 0. 0. 0. 9.54906731E7
0 IDAMP
0 ISTIFF
0 NBETAH
0 NFIELD
```

```
test07.cfg:
maxscr=1024
ISOR=0
ISOLVE=4
ISCATT=1
IQUAD=0
ILOG=0
IDIAG=0
IRR=0
MONITR=0
NUMHDR=1
IALTFRC=2
USERID_PATH=\WAMITv6    (directory for *.exe, *.dll, and userid.wam)
```

A.8 ELASTIC COLUMN WITH GENERALIZED MODES – TEST08

This test run evaluates the force coefficients and RAO's for a bottom-mounted vertical cylinder of circular cross-section, with four bending modes defined by shifted Jacobi polynomials. The hydroelastic analysis of these bending modes is analyzed using the generalized body mode option described in Chapter 8. Further details are given in Reference [13]. The cylinder extends from the free surface, where it is free, down to the bottom, at a depth of 200m, where it is clamped. The cylinder radius is 10m. Since the cylinder is clamped at the bottom the six rigid-body modes are all fixed, and specified by the values $\text{MODE}(j)=0$ in the POT file.

External mass and stiffness matrices are defined in the (Alternative 2) FRC file. The cylinder is considered to have a constant distributed mass equal to half of the displaced mass of fluid, and also a concentrated mass at the free surface equal to the displaced mass. The stiffness factor EI for the beam equation is assumed constant with the value $0.41m_0h^3$, where m_0 is the concentrated mass and h is the fluid depth. No matrix elements are required for the square submatrix $(i, j) \leq 6$ since the body is fixed in these modes. Further details for this case are given in [13].

The cylinder geometry is defined with two planes of symmetry and 512 panels on one quadrant. The length scale ULEN is specified as 1.0 to simplify the definitions of modes and output quantities. The generalized modes are defined in the subroutine DEFMOD.FOR, which is distributed to licensed users with the test files on the CD-ROM disk. The use of DEFMOD is described in Chapter 8. The output file from DEFMOD, TEST08.MOD, is included with the test files so that this test can be run without prior use of DEFMOD. Only one wave period is considered here, which coincides with resonant bending motion of the cylinder.

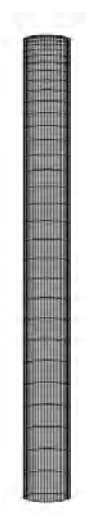

TEST08.GDF: (lines 1-8 only):

TEST08.GDF vertical cylinder, 16*32, cosine spacing at free surface

```
1.0000          9.80665
  1              1
  512
10.0000         0.000000         -200.000
 9.95185        0.980171         -200.000
 9.95185        0.980171         -190.186
10.0000         0.000000         -190.186
```

TEST08.POT:

TEST08.POT -- bending of vertical column at resonance, 200m depth

```
200.0  0.0  0.0  0.0  0.0
  0  0  0
  0  0
  0  0  0  0  0  0
  1
  6.5
  1
  0.0
```

TEST08.FRC:

TEST08.FRC file, vertical column with 4 bending modes

```
  1  1  1  1  0  0  0  0  0
  1.0
  .0000000    .0000000    1.000000
  1
  0.  0.  0.  0.  0.  0.  0.  0.  0.  0.
  0.  0.  0.  0.  0.  0.  0.  0.  0.  0.
  0.  0.  0.  0.  0.  0.  0.  0.  0.  0.
  0.  0.  0.  0.  0.  0.  0.  0.  0.  0.
  0.  0.  0.  0.  0.  0.  0.  0.  0.  0.
  0.  0.  0.  0.  0.  0.  69115.  62832.  62832.  62832.
  0.  0.  0.  0.  0.  0.  62832.  67320.  62832.  62832.
  0.  0.  0.  0.  0.  0.  62832.  62832.  66323.  62832.
  0.  0.  0.  0.  0.  0.  62832.  62832.  62832.  65688.
  0
  1
  0.  0.  0.  0.  0.  0.  0.  0.  0.  0.
  0.  0.  0.  0.  0.  0.  0.  0.  0.  0.
  0.  0.  0.  0.  0.  0.  0.  0.  0.  0.
  0.  0.  0.  0.  0.  0.  0.  0.  0.  0.
  0.  0.  0.  0.  0.  0.  0.  0.  0.  0.
```

```
0.  0.  0.  0.  0.  0.  0.  0.  0.  0.
0.  0.  0.  0.  0.  0. 103044. 412177. 824354. 1339575.
0.  0.  0.  0.  0.  0. 412177. 4430902. 9789203. 16487078.
0.  0.  0.  0.  0.  0. 824354. 9789203. 37899671. 64382041.
0.  0.  0.  0.  0.  0. 1339575. 16487078. 64382041. 162406554.
  0
  0
```

test08.cfg:

MAXSCR=1024

NUMHDR=1

NUMNAM=0

ISOR=0

IRR=0

MONITR=0

newmds=4

IALTPOT=1

IALTFRC=2

USERID_PATH=\WAMITv6 (directory for *.exe, *.dll, and userid.wam)

A.9 SPAR WITH THREE STRAKES – TEST09

This test run analyzes a circular cylinder with three spiral strakes. The strakes are modeled as zero-thickness dipole panels, following the method described in Section 5.4. The radius of the cylinder is 18m and the draft is 200m. The strake width is 3.7m. There are no planes of symmetry, due to the twist of the strakes. A total of 960 panels are used, including 672 on the cylinder plus 288 on the strakes. The excerpts from the GDF file include the first body panel and also the first dipole panel.

- In TEST09A the trimmed waterline option is used, with the parameters ITRIMWL and XTRIM specified in the file TEST09A.CFG. These parameters specify a vertical trim of 10m and a pitch angle of 10 degrees. The same TEST09.GDF file is used for both tests. Only the filenames are changed in TEST09A.POT and TEST09A.FRC. Perspective views in the untrimmed and trimmed conditions are shown below.

The FORCE run includes all options which can be evaluated without using the source formulation (ISOR=1), since the latter option cannot be used with dipole panels. The body pressure file TEST09.5p includes the pressure on the body panels, and the pressure jump on the dipole panels. The corresponding panel centroids are listed in the output file TEST09.PNL.

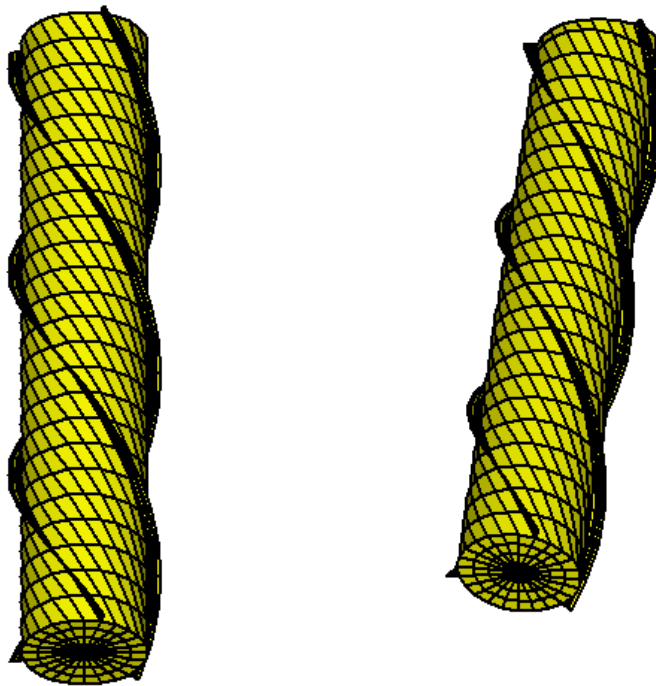

```

TEST09.GDF: (lines 1-8 and the first 5 lines for dipole panels)
SPAR R, D, W, T, NS, TWIST= 18.00 200.00 3.70 0.000000 3 1.000
18.00000 9.806650
0 0
672
18.00000 0.000000E+00 0.000000E+00
17.38667 4.658743 -8.333333
15.58846 9.000000 -8.333333
17.38667 4.658743 0.000000E+00
.
.
.
288
18.00000 0.000000E+00 0.000000E+00
17.38667 4.658743 -8.333333
18.28015 4.898150 -8.333333
18.92500 0.000000E+00 0.000000E+00
.
.
.

```

```

TEST09.POT:
TEST09.POT (Spar with three strakes)
-1. 0. 0. 0. 0. HBOT, XBODY(1-4)
1 1 IRAD, IDIFF
1 1 1 1 1 1 IMODE(1-6)
3 NPER (array PER follows)
0.1 0.5 1.0
2 NBETA (array BETA follows)
0.0 45. (end of file)

```

```

TEST09.FRC:
TEST09.FRC (Spar with three strakes)
1 1 1 1 1 1 1 2 0 IOPTN(1-9)
0.000000 VCG
1.000000 .0000000 .0000000
.0000000 1.000000 .0000000
.0000000 .0000000 1.000000 XPRDCT
0 NBETAH
2 NFIELD
23. 0. 0.
15. 15. -0.5 (end of file)

```

TEST09.CFG:

MAXSCR=1000

ISOR=0

ISOLVE=0

ISCATT=0

IQUAD=0

ILOG=0

IDIAG=0

IRR=0

MONITR=0

NUMHDR=1

IPERIO=3

NOOUT= 1 1 1 1 0 1 1 1 1

USERID_PATH=\WAMITv6 (directory for *.exe, *.dll, and userid.wam)

TEST09A.CFG:

MAXSCR=1000

ISOR=0

ISOLVE=0

ISCATT=0

IQUAD=0

ILOG=0

IDIAG=0

IRR=0

MONITR=0

NUMHDR=1

IPERIO=3

NOOUT= 1 1 1 1 0 1 1 1 1

USERID_PATH=\WAMITv6 (directory for *.exe, *.dll, and userid.wam)

ITRIMWL=1

XTRIM=10. 10. 0.

A.11 CIRCULAR CYLINDER – TEST11

The same cylinder used for the low-order TEST01 is used here with the higher-order option (ILOWHI=1). Two alternatives are used for the geometry.

In TEST11 the geometry is defined by B-splines (IGDEF=1). The parameters, knot vectors, and coefficients for each patch are contained in the file TEST11.GDF. It should be noted that the circular patches and boundaries cannot be fit exactly with B-splines; however the geometric errors are generally much smaller in this case, compared to the flat-panel representation in TEST01. For example the maximum error of any point output in the data file test11.pnl is less than $3E-5$, and the maximum error in the computed volume is $1E-5$. By comparison, using the flat-panel discretization in TEST01, the maximum error in the computed volume is $3E-3$. Thus, when the higher-order method is used, the principal errors in the results should be associated with the approximation of the potential by B-splines, as opposed to the representation of the geometry. This approximation can be systematically refined by increasing the number of panels, or by using the PANEL-SIZE option in the CONFIG.WAM (or CFG) file and reducing the value of this parameter.

In TEST11a the geometry is defined analytically by the GEOMXACT.F subroutine CIRCCYL (IGDEF=-1). The radius and draft of the cylinder are input in TEST11a.GDF. The parameter INONUMAP=0 specifies uniform mapping. Comparison of the output files with TEST01 and TEST11 confirms the statements above regarding accuracy. Most of the output data from TEST11 and TEST11a agree to at least five decimals, except for the third wave period which coincides with an irregular frequency.

In TEST11b the geometry is defined analytically, in the same manner as for TEST11a, except that nonuniform mapping is specified by the parameter INONUMAP=1 as explained in Section 6.8. This modification gives a more accurate solution near the corner and waterline, which is particularly beneficial for the pressure drift force evaluation. Comparison between the outputs for the momentum and pressure drift force shows that the results are more consistent in this case, compared to the use of uniform mapping in TEST11a. More extensive comparisons for the same geometry are included in Reference 24.

TEST11c illustrates the use of the option IGDEF=2, where the geometry is described by MultiSurf (see Section 6.7 and Appendix 2). In this case the same nonuniform mapping is used as in TEST11b, using the relabeling technique in MultiSurf. Comparison of the results with TEST11b indicates that they are practically identical.

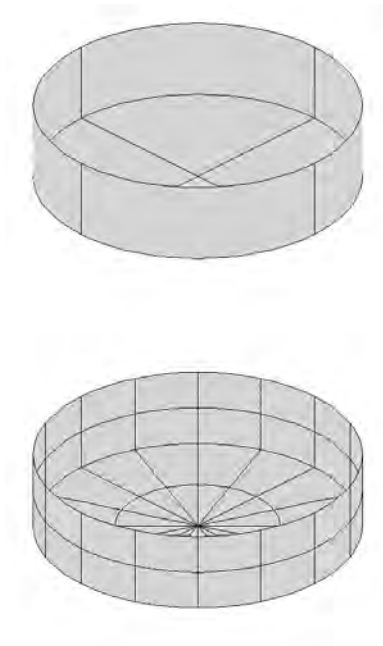

TEST11.GDF: (lines 1-8 only):

```

TEST11 cylinder R=1 T=0.5 defined by B-splines (IGDEF=1)
1. 9.80665 ULEN GRAV
1 1      ISX ISY
2 1      NPATCH, IGDEF
      4      2
      4      4
-1.0000000000000000      -1.0000000000000000      -1.0000000000000000
-1.0000000000000000      -0.5000000000000000      0.0000000000000000E+000

```

TEST11.SPL:

```

TEST11 cylinder R=1 T=0.5 defined by B-splines (IGDEF=1)
4 2      NU NV (Patch 1, side u azimuthal v vertical)
4 2      NU NV (Patch 2, bottom u azimuthal v radial)

```

TEST11.POT:

```

TEST11.POT Cylinder R=1, T=0.5, igdef=1
-1.
1      1      IRAD, IDIFF

```

```

3                                NPER (array PER follows)
8.971402 2.006403 1.003033
1                                NBETA (array BETA follows)
0.
1                                NBODY
test11.gdf
0. 0. 0. 0.                      XBODY
1 1 1 1 1 1                      IMODE(1-6)
0                                NEWMDS

```

```

TEST11.FRC:
TEST11.FRC Cylinder R=1, T=0.5, igdef=1
1 1 1 1 3 1 1 2 2 IOPTN(1-9)
0.000000 VCG
1.000000 .0000000 .0000000
.0000000 1.000000 .0000000
.0000000 .0000000 1.000000 XPRDCT
0 NBETAH
2 NFIELD
1.5 0. 0.
1.5 0. -0.5 (end of file)

```

```

test11.cfg:
ILOWHI=1
IALTPOT=2
IRR=0
ISOLVE=2
KSPLIN=3
IQUADO=3
IQUADI=4
IPERIO=1
MONITR=0
NOOUT= 1 1 1 1 0 1 1 1 1
NUMHDR=1
USERID_PATH=\WAMITv6 (directory for *.exe, *.dll, and userid.wam)

```

TEST11A.GDF: (lines 1-8 only):

TEST11a cylinder R=1 T=0.5 -- analytic geometry, uniform mapping

```
1. 9.80665 ULEN GRAV
1 1 ISX ISY
2 -1 NPATCH IGDEF
2 NLINES
1.0 0.5 RADIUS, DRAFT
0 INONUMAP (uniform mapping)
```

TEST11A.SPL:

TEST11a.spl - cylinder R=1 T=0.5 -- analytic geometry (npatch=2)

```
4 2 NU NV (Patch 1, side u azimuthal v vertical)
4 2 NU NV (Patch 2, bottom u azimuthal v radial)
```

TEST11A.POT:

TEST11A.POT Cylinder R=1, T=0.5, igdef=-1

```
-1.
1 1 IRAD, IDIFF
2 NPER (array PER follows)
8.971402 2.006403
2 NBETA (array BETA follows)
0. 45.
1 NBODY
test11a.gdf
0. 0. 0. 0. XBODY
1 1 1 1 1 1 IMODE(1-6)
0 NEWMDS
```

TEST11A.FRC:

TEST11a.FRC Cylinder R=1, T=0.5, igdef=-1

```
1 1 1 1 3 1 1 2 2 IOPTN(1-9)
0.000000 VCG
1.000000 .0000000 .0000000
.0000000 1.000000 .0000000
.0000000 .0000000 1.000000 XPRDCT
0 NBETAH
2 NFIELD
1.5 0. 0.
1.5 0. -0.5 (end of file)
```

test11a.cfg:

```
ipltdat=5
ILOWHI=1
```

IALTPOT=2
IRR=0
ISOLVE=2
KSPLIN=3
IQUADO=3
IQUADI=4
IPERIO=1
MONITR=0
NUMHDR=1
NOOUT= 1 1 1 1 0 1 1 1 1
USERID_PATH=\WAMITv6 (directory for *.exe, *.dll, and userid.wam)

```

TEST11B.GDF: (lines 1-8 only):
TEST11a cylinder R=1 T=0.5 -- analytic geometry, nonuniform mapping
1. 9.80665 ULEN GRAV
1 1 ISX ISY
2 -1 NPATCH IGDEF
2 NLINES
1.0 0.5 RADIUS, DRAFT
1 INONUMAP (nonuniform mapping)

```

```

TEST11B.POT:
TEST11B.POT Cylinder R=1, T=0.5, igdef=-1
-1.
1 1 IRAD, IDIFF
2 NPER (array PER follows)
8.971402 2.006403
2 NBETA (array BETA follows)
0. 45.
1 NBODY
test11b.gdf
0. 0. 0. 0. XBODY
1 1 1 1 1 1 IMODE(1-6)
0 NEWMDS

```

```

TEST11B.SPL:
TEST11b.spl - cylinder R=1 T=0.5 -- analytic geometry (npatch=2)
4 2 NU NV (Patch 1, side u azimuthal v vertical)
4 2 NU NV (Patch 2, bottom u azimuthal v radial)

```

```

TEST11B.FRC:
TEST11B.FRC Cylinder R=1, T=0.5, igdef=-1
1 1 1 1 3 1 1 2 2 IOPTN(1-9)
0.000000 VCG
1.000000 .0000000 .0000000
.0000000 1.000000 .0000000
.0000000 .0000000 1.000000 XPRDCT
0 NBETAH
2 NFIELD
1.5 0. 0.
1.5 0. -0.5 (end of file)

```

```

test11B.cfg:
ILOWHI=1
IALTPOT=2
IRR=0

```

ISOLVE=2
KSPLIN=3
IQUADO=3
IQUADI=4
IPERIO=1
MONITR=0
NUMHDR=1
NOOUT= 1 1 1 1 0 1 1 1 1
USERID_PATH=\WAMITv6 (directory for *.exe, *.dll, and userid.wam)

```

TEST11C.GDF: (lines 1-8 only):
TEST11 cylinder R=1 T=0.5 -- MultiSurf .ms2 input, nonuniform mapping
1. 9.80665 ULEN GRAV
1 1 ISX ISY
0 2 NPATCH IGDEF
3 NLines
TEST11C.MS2 (name of .ms2 file)
* default wetted surface (use all patches)
0 0 0 default settings: FAST, DivMult, outward normal

```

```

TEST11C.POT:
TEST11C.POT Cylinder R=1, T=0.5, igdef=-1
-1.
1 1 IRAD, IDIFF
2 NPER (array PER follows)
8.971402 2.006403
2 NBETA (array BETA follows)
0. 45.
1 NBODY
test11c.gdf
0. 0. 0. 0. XBODY
1 1 1 1 1 1 IMODE(1-6)
0 NEWMDS

```

```

TEST11C.SPL:
TEST11c.spl - cylinder R=1 T=0.5 -- analytic geometry (npatch=2)
4 2 NU NV (Patch 1, side u azimuthal v vertical)
4 2 NU NV (Patch 2, bottom u azimuthal v radial)

```

```

TEST11C.MS2:
MultiSurf 1.23
// Truncated cylinder for base HIPAN example
// Full cosine spacing on side_surf using type-3 BLoftSurf (analytic)
// Half cosine spacing on bottom
Units: m kg
Symmetry: x y
Extents: -1.000 -1.000 -0.500 1.000 1.000 0.000
View: -20.00 120.00 0
Places: 3
Layers: FFFFFFFFF FFFFFFFFF FFFFFFFFF FFFFFFFFF FFFFFFFFF FFFFFFFFF FFFFFFFFF FFFFFFFFF
DivMult: 1
BeginModel;
AbsPoint top 14 1 / 0.000 0.000 0.000 ;
EulerFrame F0 15 1 / top * 0.0000 0.0000 0.0000 ;

```

```

FrameAbsPt draft 15 1 / F0 0.000 0.000 -0.500 ;
FrameRelPt radius 15 1 / F0 draft 1.000 0.000 0.000 ;
Line axis 6 1 1x1 / * draft top ;
Helix chine 11 1 8x4 / * radius axis 0.000000 90.0000 ;
Plane2 top_plane 7 1 / top draft ;
ProjCurve top_edge 11 1 8x4 / * chine top_plane ;
ObjectList wetted_surfs /
    { side_surf bottom_surf } ;
BLoftSurf bottom_surf 6 3 8x4 4x4 1 / * 2
    { chine chine draft } ;
BLoftSurf side_surf 2 3 8x4 4x4 1 / * 3
    { top_edge top_edge chine chine } ;
EndModel;

```

TEST11C.FRC:

```

TEST11C.FRC Cylinder R=1, T=0.5, igdef=-1
1 1 1 1 3 1 1 2 2 IOPTN(1-9)
0.000000 VCG
1.000000 .0000000 .0000000
.0000000 1.000000 .0000000
.0000000 .0000000 1.000000 XPRDCT
0 NBETAH
2 NFIELD
1.5 0. 0.
1.5 0. -0.5 (end of file)

```

test11C.cfg:

```

ILOWHI=1
IALTPOT=2
IRR=0
ISOLVE=2
KSPLIN=3
IQUADO=3
IQUADI=4
IPERIO=1
MONITR=0
NUMHDR=1
NOOUT= 1 1 1 1 0 1 1 1 1
USERID_PATH=\WAMITv6 (directory for *.exe, *.dll, and userid.wam)

```

A.12 IRREGULAR-FREQUENCY REMOVAL – TEST12

TEST12 is the higher-order analog of TEST02, intended to illustrate the removal of irregular-frequency effects using the higher-order method. As in TEST11a, the geometry is defined analytically (IGDEF=-1) and the dimensions are input in the file TEST12.GDF. In this case NPATCH=3 is specified, where the additional patch corresponds to the interior free surface as required for the irregular-frequency option. The figures below illustrate the extra patch and panels.

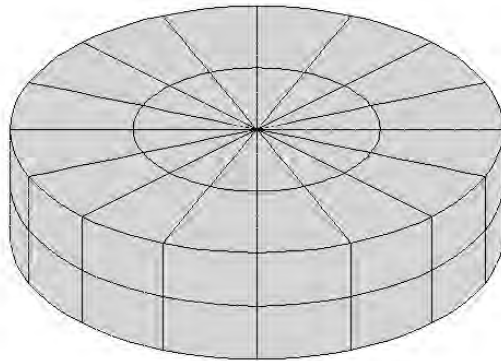
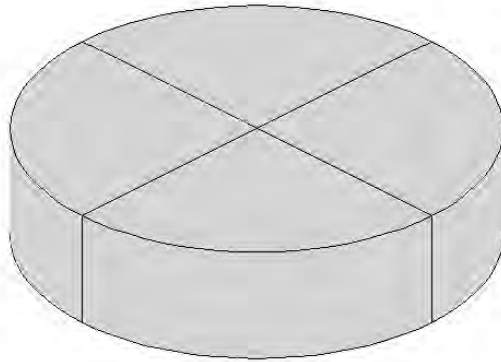

TEST12.GDF:

TEST12 cylinder R=1 T=0.5 -- analytic geometry (npatch=3)
1. 9.80665 ULEN GRAV
1 1 ISX ISY
3 -1 NPATCH IGDEF
2 NLINES
1.0 0.5 RADIUS, DRAFT
0 INONUMAP (uniform mapping)

TEST12.SPL:

TEST12.spl - cylinder R=1 T=0.5 -- analytic geometry (npatch=3)
4 2 NU NV (Patch 1, side u azimuthal v vertical)
4 2 NU NV (Patch 2, bottom u azimuthal v radial)
4 2 NU NV (Patch 3, interior free surface)

TEST12.POT:

TEST12.POT Cylinder R=1, T=0.5, igdef=-1, npatch=3 (IRR=1)
-1.
1 1 IRAD, IDIFF
3 NPER (array PER follows)
8.971402 2.006403 1.003033
2 NBETA (array BETA follows)
0. 45.
1 NBODY
test12.gdf
0. 0. 0. 0. XBODY
1 1 1 1 1 1 IMODE(1-6)
0 NEWMDS

TEST12.FRC:

TEST12.FRC Cylinder R=1, T=0.5, igdef=-1 (irr=1)
1 1 1 1 3 1 1 2 2 IOPTN(1-9)
0.000000 VCG
1.000000 .0000000 .0000000
.0000000 1.000000 .0000000
.0000000 .0000000 1.000000 XPRDCT
0 NBETAH
2 NFIELD
1.5 0. 0.
1.5 0. -0.5 (end of file)

test12.cfg:

ILOWHI=1
IALTPOT=2

IRR=1
ILOG=1
ISOLVE=1
KSPLIN=3
IQUADO=3
IQUADI=4
IPERIO=1
MONITR=0
NUMHDR=1
NOOUT= 1 1 1 1 0 1 1 1 1
USERID_PATH=\WAMITv6 (directory for *.exe, *.dll, and userid.wam)

A.13 MULTIPLE BODIES – TEST13

This test uses the same cylinder and spheroid as in the low-order TEST05. IALTPOT=2 is used to specify the separate input files TEST13C.GDF and TEST13S.GDF. TEST13C uses IGDEF=-1 as in TEST11a. TEST13S.GDF uses the ELLIPSOID subroutine (IGDEF=-4) with the semi-axes (2.0, 0.25, 0.25) specified. The same separate FRC files TEST05C, TEST05S are used with IALTFRC=3. The vector IALTFRCN is included in TEST13.CFG to indicate that IALTFRC=1 in the separate FRC files for each body. (Normally it is necessary to duplicate the FRC files for analogous runs, as for example in TEST01 and TEST11, since the output filenames are assigned based on the FRC filename. This is not necessary for individual FRC files for each body when multiple bodies are analyzed, since these do not affect the output filenames.)

The option is used to evaluate the mean drift force and moment using a control surface, following the instructions in Chapter 14. The parameter ICTRSURF=1 is assigned in the CFG file. The control surfaces surrounding the cylinder and spheroid are defined by the input files TEST13c.csf and TEST13s.csf. These control surfaces are generated by the subroutines CIRCYL_CS and ELLIPSOID_CS in the GEOMXACT DLL library. The surfaces generated by these subroutines include the portion of the free surface between the body and outer control surface. The corresponding output for the mean drift force and moment is contained in the file TEST13.9c.

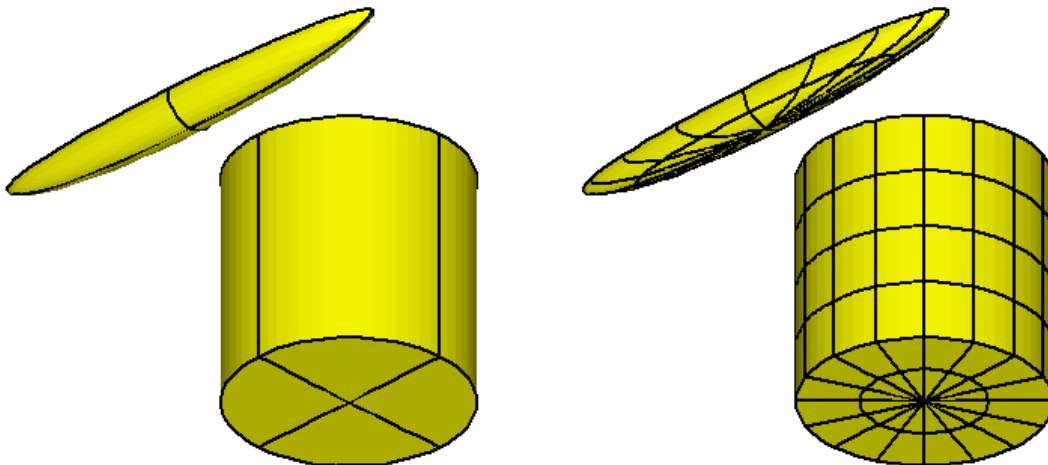

TEST13c.GDF:

TEST13C cylinder R=1 T=2 -- analytic geometry (npatch=2)

```
1. 9.80665 ULEN GRAV
1 1 ISX ISY
2 -1 NPATCH IGDEF
2 NLINES
1.0 2.0 RADIUS, DRAFT
0 INONUMAP (uniform mapping)
```

TEST13s.GDF:

TEST13S spheroid a=2, b=c=0.25 -- igdef=-4

```
1. 9.80665 ULEN GRAV
1 1 ISX ISY
1 -4 NPATCH IGDEF
1 NLINES
2.0 0.25 0.25 A, B, C
```

TEST13C.SPL:

TEST13C cylinder R=1 T=2 -- analytic geometry (npatch=2)

```
4 4 NU NV (side)
4 2 NU NV (bottom)
```

TEST13S.SPL:

TEST13S spheroid A=2 B=C=.25 -- analytic geometry (npatch=1)

```
4 2 NU NV
```

TEST13.POT:

TEST13.POT -- Cylinder + spheroid, ILOWHI=1

```
-1.
1 1 IRAD, IDIFF
2 NPER (array PER follows)
1.5 2.0
1 NBETA (array BETA follows)
0.
2 NBODY
test13c.gdf
1.25 0.0 0.0 0.0 XBODY
1 1 1 1 1 1 IMODE(1-6)
0 NEWMDS
test13s.gdf
-0.5 0.0 0.0 90.0 XBODY
1 1 1 1 1 1 IMODE(1-6)
0 NEWMDS
```

```

TEST13.FRC:
TEST13.FRC -- Cylinder + spheroid, ILOWHI=1
  1  1  1  1  0  1  1  1  1
  1.0
test05c.frc
test05s.frc
  0
  1
  0. 0. 0.

```

```

TEST05c.FRC:
CYL.FRC
  0  0  0  0  0  0  0  0  0
0.000000
1.000000  .0000000  .0000000
.0000000  1.000000  .0000000
.0000000  .0000000  1.000000
  0
  0

```

```

TEST05s.FRC:
SPD.FRC
  0  0  0  0  0  0  0  0  0
0.000000
1.000000  .0000000  .0000000
.0000000  1.000000  .0000000
.0000000  .0000000  1.000000
  0
  0

```

```

TEST13c.csf:
cylinder R=1.2 T=2.2 -- analytic CONTROL SURFACE (npatch=3)
1 ILOWHICSF
1 1 ISX ISY
3 -1001 1. NPATCH ICDEF PSZCSF
2
1.2 2.2 1.0 RADIUS, DRAFT, Inner radius
0 UNIFORM MAPPING

```

```

TEST13s.csf:
ELLIPSOID CONTROL SURFACE defined by subroutine ELLIPSOID_CS
1 ILOWHICSF
1 1 ISX ISY
2 -1003 1. NPATCH IGDEF PSZCSF
2 NLines
2.2 0.3 0.3 A, B, C (semi-axes of outer control surface)
2.0 0.25 (semi-axes of body waterline)

```

```

test13.cfg:
IPLTDAT=4
maxscr=1024
ILOWHI=1
IALTPOT=2
IRR=0
ISOLVE=2
KSPLIN=3
IQUADO=3
IQUADI=4
IPERIO=1
NUMHDR=1
NOOUT=0 1 1 1 0 1 1 1 1
IALTFRC = 3 ! Alternative Form 3 FRC
IALTFRCN= 1 1
ICTRSURF=1 ! Evaluate control surface drift forces
USERID_PATH=\WAMITv6 (directory for *.exe, *.dll, and userid.wam)

```

- TEST13A illustrates the use of trimmed waterlines, as specified by the last three lines of the file TEST13A.CFG. The cylinder is raised vertically by 1m, and rotated about the pitch axis by 15 degrees. The options IRR=3 and IRR=1 are used to remove irregular frequency effects, as described in Section 9.4. The interior free surface of the spheroid is defined by the GDF file and subroutine ELLIPSOID, with IRR=1 (See Sections 6.8 and 9.1). The interior free surface of the trimmed cylinder is defined automatically by the program, based on the trimmed waterline, with IRR=3 (See Section 9.4). (Since the cylinder is trimmed the waterplane is elliptical, and the IRR=1 extension of CIRCCYL in GEOMXACT is not valid.) Note that NPATCH=2 is assigned in test13as.gdf, to provide for the interior free surface, and test13as.spl includes the spline parameters NU,NV for this extra patch. Conversely for the cylinder the input files test13ac.gdf and test13ac.spl do not include the extra patch since this is added by the program using IRR=3.

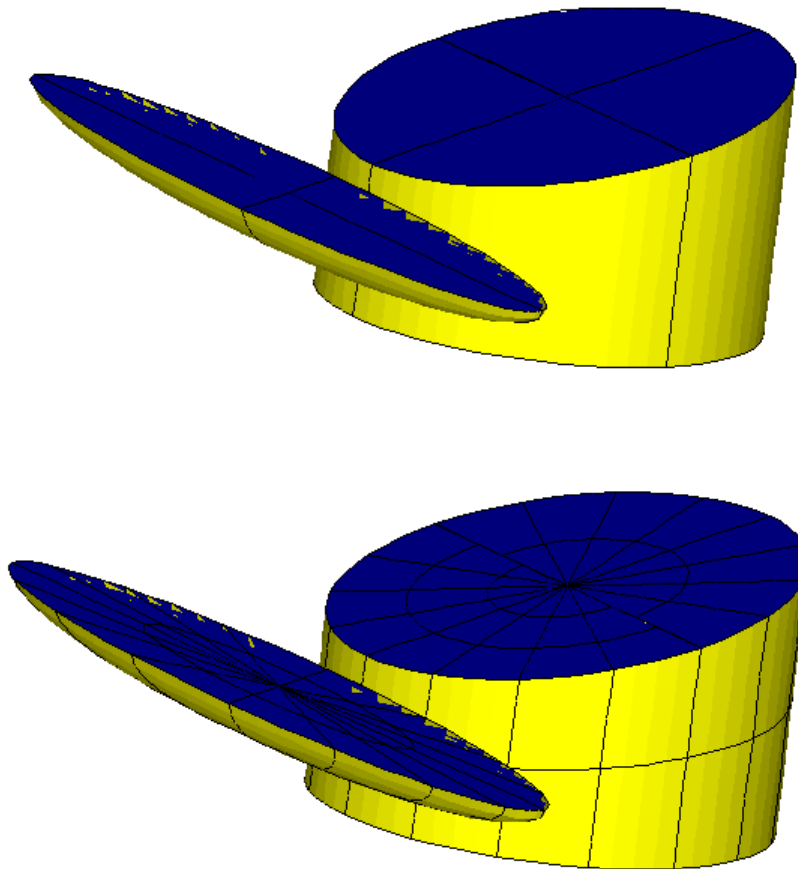

TEST13A.POT:

```
TEST13A.POT -- Trimmed Cylinder + spheroid, IRR=3
-1.
1          1          IRAD, IDIFF
2          NPER (array PER follows)
1.00  2.00
1          NBETA (array BETA follows)
0.
2          NBODY
test13ac.gdf
1.25 0.0 0.0 0.0      XBODY
1 1 1 1 1 1          IMODE(1-6)
0          NEWMDS
test13as.gdf
-0.5 0.0 0.0 90.0    XBODY
1 1 1 1 1 1          IMODE(1-6)
0          NEWMDS
```

TEST13AC.GDF:

```
test13ac.gdf -- Cylinder, trimmed, no interior fs
1. 9.80665 ULEN GRAV
1 1          ISX ISY
2 -1        NPATCH IGDEF
2          NLines
1.0 2.0     RADIUS, DRAFT
0          UNIFORM MAPPING
```

TEST13AS.GDF:

```
test13as.gdf -- untrimmed spheroid with interior fs for IRR=1
1. 9.80665 ULEN GRAV
1 1          ISX ISY
2 -4        NPATCH IGDEF
1          NLines
2.0 0.25 0.25  A, B, C
```

TEST13AC.SPL:

```
TEST13ac cylinder R=1 T=2 -- analytic geometry (npatch=2)
4 2          NU NV (side)
4 2          NU NV (bottom)
```

TEST13AS.SPL:

```
test13as.spl -- untrimmed spheroid with interior fs for IRR=3
4 2          body patch  NU NV
4 2          interior fs  NU NV
```

TEST13A.FRC:

TEST13a.FRC -- Cylinder + spheroid, trimmed waterlines

1 1 1 1 0 1 1 1 1

1.0

test05c.frc

test05s.frc

0

1

0. 0. 0.

TEST13A.CFG:

IPLTDAT=4

maxscr=1024

ILOWHI=1

IALTPOT=2

IRR(1)=3

IRR(2)=1

ILOG=1

ISOLVE=1

KSPLIN=3

IQUADO=3

IQUADI=4

IPERIO=1

NUMHDR=1

NOOUT=0 1 1 1 0 1 1 1 1

IALTFRC = 3 ! Alternative Form 3 FRC

IALTFRCN= 1 1

USERID_PATH=\WAMITv6 (directory for *.exe, *.dll, and userid.wam)

itrimwl=1 trim waterline

xtrim(1)= 1.0 15. 0.

xtrim(2)= 0.0 0. 0.

A.14 ISSC TLP – TEST14

The subroutine TLP (IGDEF=-9) is used to generate the ISSC TLP with the dimensions specified in TEST14.GDF. Except for the geometry, the inputs correspond to the low-order test runs TEST06 and TEST07. As explained in Appendix A.6 a warning message is displayed for Options 8 and 9 since IDIFF=0.

For TEST14A, TEST14A.CFG TEST14A.POT and TEST14A.FRC are used to output data to be used as input to F2T. TEST14.GDF and TEST14.SPL are used without change. TEST14A.POT has zero and infinite frequencies and 98 uniformly spaced frequencies. In CFG, IPERIO=2 is specified. In FRC, IOPTN(4) is set to output RAOs.

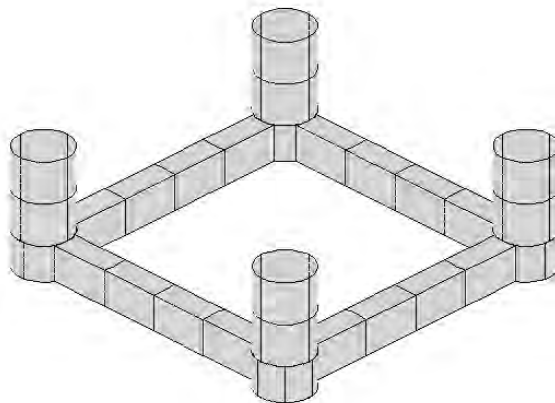
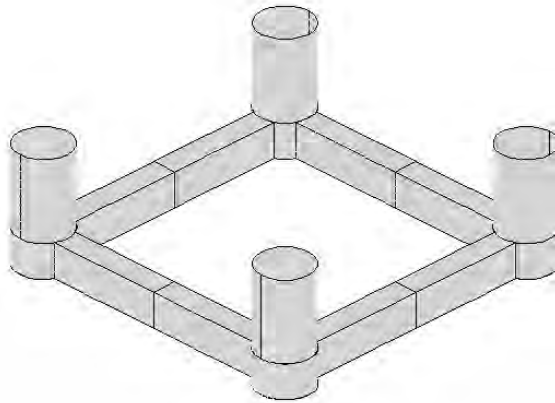

TEST14.GDF:

```
TEST14 -- ISSC TLP (ILOWHI=1)
43.125  9.80665          ULEN GRAV
1  1          ISX  ISY
12 -9          NPATCH, IGDEF
2          NLINES
8.435  35.    43.125    RADIUS  DRAFT  HSPACE
7.5    10.5          WIDTH  HEIGHT
```

TEST14.SPL:

```
TEST14 -- ISSC TLP (ILOWHI=1)
1  2          NU NV patch 1
1  2          NU NV patch 2
1  2          NU NV patch 3
1  2          NU NV patch 4
1  2          NU NV patch 5
1  2          NU NV patch 6
1  2          NU NV patch 7
1  2          NU NV patch 8
4  1          NU NV patch 9
4  2          NU NV patch 10
4  1          NU NV patch 11
1  1          NU NV patch 12
```

TEST14.POT:

```
TEST14 -- ISSC TLP (ILOWHI=1)
450
0          0          IRAD, IDIFF
3          NPER (array PER follows)
5. 10. 15.
1          NBETA (array BETA follows)
0.
1          NBODY
test14.gdf
0. 0. 0. 0.          XBODY
1  0  1  0  1  0          IMODE(1-6)
0          NEWMDS
```

TEST14.FRC:

```
TEST14 -- ISSC TLP (ILOWHI=1, IALTFRC=2)
1  1  1 -2  0  0  0  0  0  IOPTN (IOPTN(4)<0 signifies fixed modes)
6          NDFR
1  1  0  0  0  1          IMODE
1.          RHO
```

```

0. 0. 3.0          XCG
1                   IMASS
  53066.4    0.    0.    0.    159199.2    0.
    0.    53066.4    0. -159199.2    0.    0.
    0.    0.    53066.4    0.    0.    0.
    0. -159199.2    0.  8.0201552E7    0.    0.
  159199.2    0.    0.    0.    8.0201552E7    0.
    0.    0.    0.    0.    0.  9.54906731E7
0                   IDAMP
0                   ISTIFF
0                   NBETAH
0                   NFIELD

```

test14.cfg:

```

ipltdat=5
MAXSCR=1024
ILOWHI=1
IALTPOT=2
IRR=0
ISOLVE=1
IQUADI=4
IQUADO=3
KSPLIN=3
NUMHDR=1
IALTFRC=2
USERID_PATH=\WAMITv6 (directory for *.exe, *.dll, and userid.wam)

```

TEST14A.POT:

TEST14A -- ISSC TLP (ILOWHI=1)

```
450
0          0          IRAD, IDIFF
-101          NPER (array PER follows)
-0.05 0.05
1          NBETA (array BETA follows)
0.
1          NBODY
test14.gdf
0. 0. 0. 0.          XBODY
1 0 1 0 1 0          IMODE(1-6)
0          NEWMDS
```

TEST14A.FRC:

TEST14A -- ISSC TLP (ILOWHI=1, IALTFRC=2)

```
1 1 1 1 0 0 0 0 0 IOPTN
1.          RHO
0. 0. 3.0          XCG
1          IMASS
53066.4      0.          0.          0.          159199.2      0.
0. 53066.4      0. -159199.2      0.          0.
0. 0. 53066.4      0.          0.          0.
0. -159199.2      0. 8.0201552E7      0.          0.
159199.2      0.          0.          0. 8.0201552E7      0.
0. 0.          0.          0.          0. 9.54906731E7
0          IDAMP
0          ISTIFF
0          NBETAH
0          NFIELD
```

TEST14A.CFG:

```
MAXSCR=1024
ILOWHI=1
IALTPOT=2
IRR=0
ISOLVE=1
IQUADI=4
IQUADO=3
KSPLIN=3
NUMHDR=1
IALTFRC=2
IPERIO=2
USERID_PATH=\WAMITv6 (directory for *.exe, *.dll, and userid.wam)
```

A.15 SEMI-SUB – TEST15

The subroutine SEMISUB (IGDEF=-10) is used to generate a Semi-submersible with the dimensions specified in TEST15.GDF. There are five columns on each pontoon, as shown in the figures below. For this structure a total of 10 patches are required. If NPATCH=11, extensions of the pontoons can be included as explained in the subroutine comments.

- The option 9c is used to evaluate the drift force and moment from the method described in Chapter 14 by setting the parameter ICTRSURF=1 in the CFG file. The control surface is defined by the program, using the automatic method described in Section 14.5, with the input parameters specified in the CSF file. The outer control surface is a rectangular box, and three inner partitions are defined to separate the columns, as discussed in Example 4 of Section 14.5.
- TEST15a illustrates the option to use an external RAO file, as explained in Section 3.12. In this illustration the external RAO file test15a.rao is the same as the output file test15.rao except that the order of the heave and pitch RAO's is reversed. Thus the drift force outputs in TEST15 and TEST15a are the same, except that the evaluation of the mean drift forces using a control surface is omitted in TEST15a to reduce the computation time.

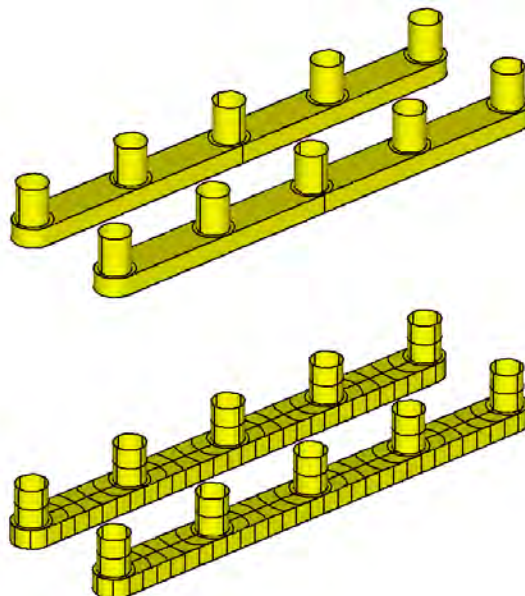

```

test15.gdf:
TEST15 Semi-sub, NCOL=5, IGDEF=-10
1. 9.80665 ULEN GRAV
1 1 ISX ISY
10 -10 NPATCH IGDEF
2 NLINES
260. 20. 40. -30. -20. XL, Y1, Y2, Z1, Z2
60. 8. 5 DCOL, RCOL, NCOL

```

```

test15.spl:
TEST15 Semi-sub, NCOL=5, IGDEF=-10
9 2 NU NV (patch 10+32 - pontoon bottom)
32 1 NU NV (patch 9+32 - pontoon side)
2 2 NU NV (patch 1+32 - column 3)
2 1 NU NV (patch 2+32 - annulus 3)
5 2 NU NV (patch 3+32 - between annulus 3&4)
4 2 NU NV (patch 4+32 - column 4)
4 1 NU NV (patch 5+32 - annulus 4)
5 2 NU NV (patch 6+32 - between annulus 4&5)
4 2 NU NV (patch 7+32 - column 5)
4 1 NU NV (patch 8+32 - annulus 5)

```

```

test15.pot:
TEST15 Semi-sub with five columns on each pontoon
-1.
0 1 IRAD, IDIFF
1 NPER (array PER follows)
18.0
1 NBETA (array BETA follows)
180.
1 NBODY
test15.gdf
0. 0. 0. 0. XBODY
0 0 1 0 1 0 IMODE(1-6)
0 NEWMDS

```

```

test15.frc:
TEST15 Semi-sub with five columns on each pontoon
1 1 1 1 0 0 0 1 1
0.0000
20.0 0.0 0.0
0. 60.0 0.0
0 0. 60.0
0

```

0

test15.csf:

test15.csf semi sub, outer box 150*60*40

1 ILOWHICSF

1 1 ISX ISY

0 0 10. NPATCH ICDEF PSZCSF (1st two indicate this is automatic)

0.0 40.0 RADIUS, DRAFT of outer box

4 NPART

3 nv0

150.0 0.0

150.0 60.0

0.0 60.0 end of partition line 0 (outer boundary of control surface)

3 nv1

0.0 0.0

30.0 0.0

30.0 50.0

4 nv2

30.0 50.0

30.0 0.0

90.0 0.0

90.0 50.0

3 nv3

90.0 50.0

90.0 0.0

150.0 0.0 end of partition line column 3

test15.cfg:

iplttdat=1

ISOLVE=1

IPERIO=1

NUMHDR=1

KSPLIN=3

IQUADI=4

IQUADO=3

ILOWHI=1

IALTPOT=2

IRR=0

USERID_PATH=\WAMITv6 (directory for *.exe, *.dll, and userid.wam)

ictrsurf=1

Modified files for test15a:

fnames.wam:
test15a.cfg
test15.pot
test15a.frc

test15a.cfg:
ipltdat=1
ISOLVE=1
IPERIO=1
NUMHDR=1
KSPLIN=3
IQUADI=4
IQUADO=3
ILOWHI=1
IALTPOT=2
IRR=0
USERID_PATH=\WAMITv6 (directory for *.exe, *.dll, and userid.wam)
ictrsurf=0
IREADRAO=2
IPOTEN=0

test15a.rao:
test15a.rao input for FORCE RUN of a variation of test15 using external rao.
0.180000E+02 0.180000E+03 5
8.168581E-03 -9.062335E+01 -8.886903E-05 -8.168098E-03
0.180000E+02 0.180000E+03 3
4.738395E-01 -1.829308E+00 4.735980E-01 -1.512591E-02

test15a.frc: (identical to test15.frc except for the filename)

TEST15 Semi-sub with five columns on each pontoon
1 1 1 1 0 0 0 1 1
0.0000
20.0 0.0 0.0
0. 60.0 0.0
0 0. 60.0
0
0

A.16 BARGE WITH BENDING MODES – TEST16

The test runs TEST16 and TEST16a analyze the structural response of a rectangular barge with total length 80m, beam 10m, and draft 5m. Eight free-free beam modes are included to analyze the elastic deformation of the barge. These mode shapes are defined in the subroutines NEWMODES and DEFINE, as explained in Chapter 8. The response amplitude of each mode is included in the RAO's.

In TEST16 the subroutine BARGE (IGDEF=-5) is used. The half-length, half-beam and draft are specified in TEST16.GDF. In TEST16a the option IGDEF=0 is used, with the vertices of the patches specified in TEST16a.GDF in the same format as for low-order panels.

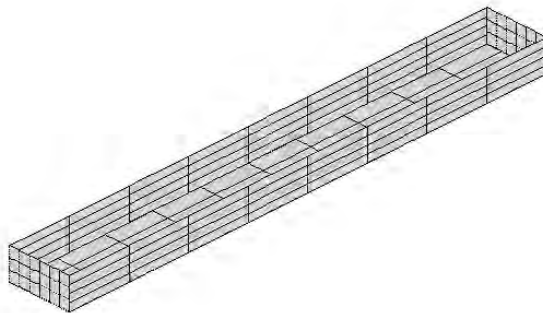
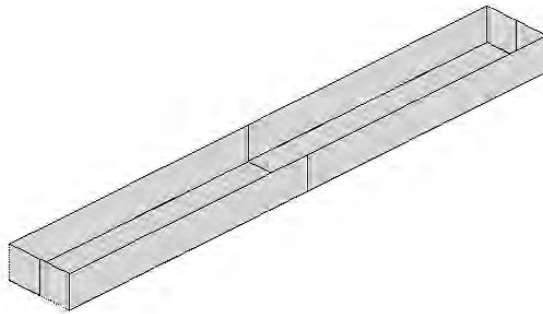

TEST16.GDF:
 TEST16 elastic barge
 1. 9.80665 ULEN GRAV
 1 1 ISX ISY
 3 -5 NPATCH IGDEF
 1 NLINES
 40.0 5.0 5.0 half-length, half-beam, draft

TEST16.SPL:
 TEST16 elastic barge
 3 3 NU NV (end)
 4 4 KU KV
 5 2 (side)
 4 4
 5 2 (bottom)
 4 4
 IQUO IQVO are not specified IQUADO=3 in config.wam
 IQUI IQVI are not specified IQUADI=4 in config.wam

TEST16.POT:
 TEST16 elastic barge with 8 beam modes
 -1.
 0 0 IRAD, IDIFF
 2 NPER (array PER follows)
 7. 8.
 1 NBETA (array BETA follows)
 180.
 1 NBODY
 test16.gdf
 0. 0. 0. 0. XBODY
 1 0 1 0 1 0 IMODE(1-6)
 8 NEWMDS

TEST16.FRC:
 TEST16 elastic barge with 8 beam modes
 1 1 1 1 0 0 0 0
 1000.
 0. 0. 0.
 1
 4.00000E+06 0. 0. 0. 0. 0. 0. 0. 0. 0. 0. 0. 0. 0. 0.
 0. 0. 0. 0. 0. 0. 0. 0. 0. 0. 0. 0. 0. 0.
 0. 0. 4.E+06 0. 0. 0. 0. 0. 0. 0. 0. 0. 0. 0. 0.
 0. 0. 0. 0. 0. 0. 0. 0. 0. 0. 0. 0. 0. 0.
 0. 0. 0. 0. 2.13333E+09 0. 0. 0. 0. 0. 0. 0. 0. 0. 0.

```

0. 0. 0. 0. 0. 0. 0. 0. 0. 0. 0. 0. 0. 0. 0. 0. 0. 0.
0. 0. 0. 0. 0. 0. 0. 1.E+06 0. 0. 0. 0. 0. 0. 0. 0. 0.
0. 0. 0. 0. 0. 0. 0. 0. 1.E+06 0. 0. 0. 0. 0. 0. 0. 0.
0. 0. 0. 0. 0. 0. 0. 0. 0. 1.E+06 0. 0. 0. 0. 0. 0.
0. 0. 0. 0. 0. 0. 0. 0. 0. 0. 1.E+06 0. 0. 0. 0. 0.
0. 0. 0. 0. 0. 0. 0. 0. 0. 0. 0. 1.E+06 0. 0. 0. 0.
0. 0. 0. 0. 0. 0. 0. 0. 0. 0. 0. 0. 1.E+06 0. 0. 0.
0. 0. 0. 0. 0. 0. 0. 0. 0. 0. 0. 0. 0. 1.E+06 0. 0.
0. 0. 0. 0. 0. 0. 0. 0. 0. 0. 0. 0. 0. 0. 1.E+06
0
1
0. 0. 0. 0. 0. 0. 0. 0. 0. 0. 0. 0. 0. 0. 0. 0. 0.
0. 0. 0. 0. 0. 0. 0. 0. 0. 0. 0. 0. 0. 0. 0. 0. 0.
0. 0. 0. 0. 0. 0. 0. 0. 0. 0. 0. 0. 0. 0. 0. 0. 0.
0. 0. 0. 0. 0. 0. 0. 0. 0. 0. 0. 0. 0. 0. 0. 0. 0.
0. 0. 0. 0. 0. 0. 0. 0. 0. 0. 0. 0. 0. 0. 0. 0. 0.
0. 0. 0. 0. 0. 0. 0. 0. 0. 0. 0. 0. 0. 0. 0. 0. 0.
0. 0. 0. 0. 0. 0. 0. 6.25705E+06 0. 0. 0. 0. 0. 0. 0. 0.
0. 0. 0. 0. 0. 0. 0. 0. 4.75441E+07 0. 0. 0. 0. 0. 0. 0. 0.
0. 0. 0. 0. 0. 0. 0. 0. 0. 1.82720E+08 0. 0. 0. 0. 0. 0. 0.
0. 0. 0. 0. 0. 0. 0. 0. 0. 0. 4.99297E+08 0. 0. 0. 0. 0. 0.
0. 0. 0. 0. 0. 0. 0. 0. 0. 0. 0. 1.11419E+09 0. 0. 0. 0. 0.
0. 0. 0. 0. 0. 0. 0. 0. 0. 0. 0. 0. 2.17352E+09 0. 0. 0.
0. 0. 0. 0. 0. 0. 0. 0. 0. 0. 0. 0. 0. 3.85260E+09 0. 0.
0. 0. 0. 0. 0. 0. 0. 0. 0. 0. 0. 0. 0. 0. 6.35602E+09
0
0

```

```

test16.cfg:
ILOWHI=1
IALTPOT=2
IALTFRC=2
IRR=0
ISOLVE=1
IQUADI=5
IQUADO=4
IPERIO=1
MONITR=0
NUMHDR=1
ILOG=0
IGENMDS=16
USERID_PATH=\WAMITv6 (directory for *.exe, *.dll, and userid.wam)

```

TEST16A.GDF: (lines 1-8 only):

TEST16a elastic barge with 8 beam modes - igdef=0 (3 flat panels)

```
1.0000          9.80665
      1          1
      3          0      NPATCH, IGDEF
40.0000      0.000000      -5.00000
40.0000      5.00000      -5.00000
40.0000      5.00000      0.000000
40.0000      0.000000      0.000000      (end)
```

TEST16A.SPL:

TEST16A elastic barge with igdef=0 (patches defined by flat panels)

```
3 3      NU NV      end
4 4      KU KV
5 2      side
4 4
5 2      bottom
4 4
```

TEST16A.POT:

TEST16a elastic barge with 8 beam modes - igdef=0

```
-1.
0          0      IRAD, IDIFF
2          NPER (array PER follows)
7. 8.
1          NBETA (array BETA follows)
180.
1          NBODY
test16a.gdf
0. 0. 0. 0.      XBODY
1 0 1 0 1 0      IMODE(1-6)
8          NEWMDS
```

TEST16A.FRC:

TEST16a elastic barge with 8 beam modes (igdef=0)

```
1 1 1 1 0 0 0 0
1000.
0. 0. 0.
1
4.00000E+06 0. 0. 0. 0. 0. 0. 0. 0. 0. 0. 0. 0. 0. 0.
0. 0. 0. 0. 0. 0. 0. 0. 0. 0. 0. 0. 0. 0.
0. 0. 4.E+06 0. 0. 0. 0. 0. 0. 0. 0. 0. 0. 0. 0.
0. 0. 0. 0. 0. 0. 0. 0. 0. 0. 0. 0. 0. 0.
0. 0. 0. 0. 2.13333E+09 0. 0. 0. 0. 0. 0. 0. 0. 0. 0.
```

```

0. 0. 0. 0. 0. 0. 0. 0. 0. 0. 0. 0. 0. 0. 0. 0. 0. 0.
0. 0. 0. 0. 0. 0. 0. 1.E+06 0. 0. 0. 0. 0. 0. 0. 0. 0.
0. 0. 0. 0. 0. 0. 0. 0. 1.E+06 0. 0. 0. 0. 0. 0. 0. 0.
0. 0. 0. 0. 0. 0. 0. 0. 0. 1.E+06 0. 0. 0. 0. 0. 0.
0. 0. 0. 0. 0. 0. 0. 0. 0. 0. 1.E+06 0. 0. 0. 0. 0.
0. 0. 0. 0. 0. 0. 0. 0. 0. 0. 0. 1.E+06 0. 0. 0. 0.
0. 0. 0. 0. 0. 0. 0. 0. 0. 0. 0. 0. 1.E+06 0. 0. 0.
0. 0. 0. 0. 0. 0. 0. 0. 0. 0. 0. 0. 0. 1.E+06 0. 0.
0. 0. 0. 0. 0. 0. 0. 0. 0. 0. 0. 0. 0. 0. 1.E+06
0
1
0. 0. 0. 0. 0. 0. 0. 0. 0. 0. 0. 0. 0. 0. 0. 0. 0.
0. 0. 0. 0. 0. 0. 0. 0. 0. 0. 0. 0. 0. 0. 0. 0. 0.
0. 0. 0. 0. 0. 0. 0. 0. 0. 0. 0. 0. 0. 0. 0. 0. 0.
0. 0. 0. 0. 0. 0. 0. 0. 0. 0. 0. 0. 0. 0. 0. 0. 0.
0. 0. 0. 0. 0. 0. 0. 0. 0. 0. 0. 0. 0. 0. 0. 0. 0.
0. 0. 0. 0. 0. 0. 0. 0. 0. 0. 0. 0. 0. 0. 0. 0. 0.
0. 0. 0. 0. 0. 0. 0. 6.25705E+06 0. 0. 0. 0. 0. 0. 0. 0.
0. 0. 0. 0. 0. 0. 0. 0. 4.75441E+07 0. 0. 0. 0. 0. 0. 0. 0.
0. 0. 0. 0. 0. 0. 0. 0. 0. 1.82720E+08 0. 0. 0. 0. 0. 0. 0.
0. 0. 0. 0. 0. 0. 0. 0. 0. 0. 4.99297E+08 0. 0. 0. 0. 0. 0.
0. 0. 0. 0. 0. 0. 0. 0. 0. 0. 0. 1.11419E+09 0. 0. 0. 0. 0.
0. 0. 0. 0. 0. 0. 0. 0. 0. 0. 0. 0. 2.17352E+09 0. 0. 0.
0. 0. 0. 0. 0. 0. 0. 0. 0. 0. 0. 0. 0. 3.85260E+09 0. 0.
0. 0. 0. 0. 0. 0. 0. 0. 0. 0. 0. 0. 0. 0. 6.35602E+09
0
0

```

test16A.cfg:

```

ILOWHI=1
IALTPOT=2
IALTFRC=2
IRR=0
ISOLVE=1
IQUADI=5
IQUADO=4
IPERIO=1
MONITR=0
NUMHDR=1
ILOG=0
IGENMDS=16
USERID_PATH=\WAMITv6 (directory for *.exe, *.dll, and userid.wam)

```

A.17 CYLINDER WITH MOONPOOL – TEST17

This test run illustrates two alternative methods for analyzing bodies with moonpools. The geometry used is the circular cylinder with a concentric fluid chamber, as shown in the figure. The inner chamber of fluid, referred to as a ‘moonpool’, is open at the bottom of the cylinder to the external fluid domain. The top of the moonpool is a free surface with atmospheric pressure. One of the practical aspects of this problem is the existence of highly tuned resonant frequencies of the motion at the moonpool free surface. If the draft is comparable or large compared to the horizontal dimensions of the moonpool, the principal resonance is a ‘pumping mode’ which occurs when KT , the product of the wavenumber K and draft T is slightly less than one. Additional resonances occur in ‘sloshing modes’ at higher frequencies, corresponding approximately to standing waves inside the moonpool.

A cylinder with draft 1m is used, with the outer radius $RADIUS=0.5m$ and the inner radius $RADMP=0.25m$. The geometry in all cases is represented analytically by the subroutine `CYLMP` (`IGDEF=-7`). To clarify the behavior near resonance, the wavenumber K is input in the `POT` file with the corresponding option `IPERIO=3` specified in the `TEST17.cfg` file. Seven values of K are input in the range $0.7 \leq K \leq 1.0$ to focus on the regime including the pumping mode. The computed hydrodynamic parameters include the force coefficients, `RAO`’s, and the elevation of the free surface at the center of the moonpool.

In `TEST17` three patches are used to represent the outer surface $r=RADIUS$, the annular bottom $z=-DRAFT$, and the inner vertical surface $r=RADMP$. The free surface inside the moonpool is part of the physical free surface, and the appropriate free-surface boundary condition is satisfied automatically by the Green function as described in Chapter 12. The outputs display singular features characteristic of the resonant pumping mode. This includes large amplitudes of the heave damping and exciting force, and negative added mass in the vicinity of $KT = 0.85$. The heave `RAO` exceeds 8, and the free-surface elevation in the moonpool exceeds 6, relative to the incident wave amplitude. These very large responses are non-physical, and their existence in the computations can be attributed primarily to the neglect of viscous damping associated with flow separation at the outer and inner corners of the cylinder. This damping is only important when the vertical motions of the cylinder and/or moonpool are large. Experiments suggest that typical resonant amplitudes are on the order of 2 or 3 times the incident wave amplitude.

In order to damp the moonpool response and heave motions separately, a different physical problem is considered where a ‘lid’ is placed on the free surface of the moonpool. This lid is considered to be an extension of the body surface, and represented by an additional patch. Thus `NPATCH=4` is assigned in `TEST17a.GDF` (and used also in `TEST17b`) and the subroutine `CYLMP` assigns the patch number 4 to be the circular disc of radius $RADMP$ in the plane $Z=0$. However allowance must be made for the motions of the actual free surface relative to the body. This is done by defining appropriate generalized modes, which are nonzero only on patch 4. The most important mode is a vertical translation, assigned here in the subroutine file `NEWMODES.F` with the index $j = 7$. A more complete expansion can be introduced, but at the wavenumbers considered here and

for head-sea incidence angle it suffices to consider only a pitch rotation of the lid ($j = 8$). These two generalized modes, physically analogous to pitch and heave but defined relative to the body, are introduced via the subroutine MOONPOOL_FS in NEWMODES.F.

In test run TEST17a, the lid is assumed to be free with no external force or moment acting on it. The IALTFRC=2 option is employed, and the only external force matrix that is included in TEST17.FRC is the mass matrix of the body. This mass matrix is equivalent to the radii of gyration specified in TEST17.FRC. It can be confirmed by comparison of the outputs that the motions of the body (RAO) are virtually identical to TEST17, confirming that the representation of the moonpool free surface in this manner is legitimate. A comparison can also be made between the moonpool free surface elevation (numeric output file TEST17.6) and the response of the lid in mode 7 (RAO(7) in the numeric output file TEST17a.4), but in this comparison account must be made for the fact that RAO(7) is relative to the body motions, and thus it is necessary to compare the (complex) sum RAO(3)+RAO(7) in TEST17a with the moonpool free surface elevation in TEST17.

Finally, in TEST17b, empirical damping is introduced via the external damping matrix in TEST17b.FRC. Since this is the only difference between TEST17a and TEST17b, it is not necessary to re-run POTEN and the same TEST17a.P2F file is used for TEST17b. Thus TEST17a.pot is specified in FNAMES.17b, and IPOTEN=0 in the TEST17b.cfg file. The only nonzero elements of the external damping matrix are for heave ($j = 3$) and the lid vertical motion ($j = 7$). With these empirical damping coefficients added, more appropriate RAO's are obtained. This general approach can be refined based on experimental data. Experience with similar problems suggests that relatively crude estimates based on the observed response at resonance are sufficient to correct the response over a broad range of wave periods.

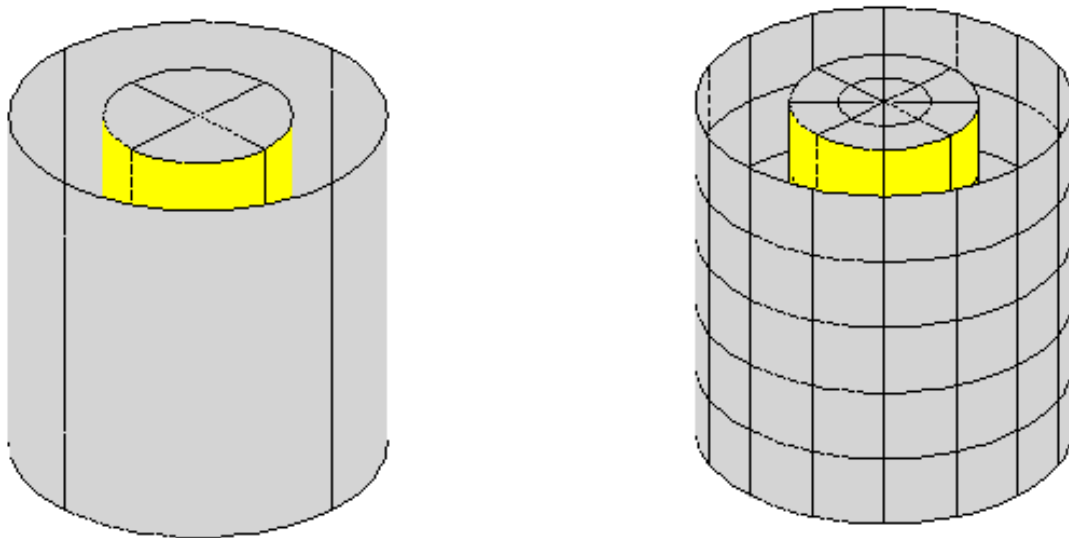

```

TEST17.GDF:
TEST17 cylinder with moonpool
1. 9.80665 ULEN GRAV
1 1 ISX ISY
3 -7 NPATCH IGDEF
1 NLines
0.5 1.0 0.25 radius, draft, moonpool radius

```

```

TEST17.POT:
TEST17 cylinder with moonpool, NPATCH=3
-1.
0 1 IRAD, IDIFF
7 NPER (array PER follows)
.7 .75 .8 .85 .9 .95 1.0
1 NBETA (array BETA follows)
180.
1 NBody
test17.gdf
0. 0. 0. 0. XBODY
1 0 1 0 1 0 IMODE(1-6)
0 NEWMDS

```

```

TEST17.FRC:
TEST17.FRC Cylinder with moonpool
1 1 1 1 0 1 0 0 0 IOPTN(1-9)
0.000000 VCG
1.000000 .0000000 .0000000
.0000000 1.000000 .0000000
.0000000 .0000000 1.000000 XPRDCT
0 NBETAH
1 NFIELD
0.0 0.0 0.0

```

```

test17.cfg:
ILOWHI=1
IALTPOT=2
IALTFRC=1
IRR=0
ISOLVE=1
PANEL_SIZE = 0.2 (use default .spl parameters)
IPERIO = 3 (input wavenumber)
NUMHDR=1
USERID_PATH=\WAMITv6 (directory for *.exe, *.dll, and userid.wam)

```

TEST17A.GDF: (lines 1-8 only):

TEST17a cylinder with moonpool -- undamped patch on free surface

```
1. 9.80665 ULEN GRAV
1 1 ISX ISY
4 -7 NPATCH IGDEF
1 NLines
0.5 1.0 0.25 radius, draft, moonpool radius
```

TEST17A.POT:

TEST17 cylinder with moonpool, NPATCH=3

```
-1.
0 1 IRAD, IDIFF
7 NPER (array PER follows)
.7 .75 .8 .85 .9 .95 1.0
1 NBETA (array BETA follows)
180.
1 NBody
test17a.gdf
0. 0. 0. 0. XBODY
1 0 1 0 1 0 IMODE(1-6)
2 NEWMDS
```

TEST17A.FRC:

TEST17a moonpool with generalized modes for free surface - no damping

```
1 1 1 1 0 0 0 0 0
1.
0. 0. 0.
1 imass (mass matrix of body)
0.589049 0.0 0.0 0.0 0.0 0.0 0.0 0.0
0.0 0.589049 0.0 0.0 0.0 0.0 0.0 0.0
0.0 0.0 0.589049 0.0 0.0 0.0 0.0 0.0
0.0 0.0 0.0 0.589 0.0 0.0 0.0 0.0
0.0 0.0 0.0 0.0 0.589 0.0 0.0 0.0
0.0 0.0 0.0 0.0 0.0 0.589 0.0 0.0
0.0 0.0 0.0 0.0 0.0 0.0 0.0 0.0
0.0 0.0 0.0 0.0 0.0 0.0 0.0 0.0
0 idamp
0 istif
0
0
```

test17A.cfg:

```
ILOWHI=1
IALTPOT=2
```

IALTFRC=2
ISOLVE=1
PANEL_SIZE = 0.2 (use default .spl parameters)
IPERIO = 3 (input wavenumber)
IRR=0
ILOG=1
NUMHDR=1
IGENMDS=17
USERID_PATH=\WAMITv6 (directory for *.exe, *.dll, and userid.wam)

TEST17B.FRC:

TEST17b cylinder+moonpool, generalized modes, damping b33=.4, b77=.1

1 1 1 1 0 0 0 0 0

1.

0. 0. 0.

1 imass (mass matrix of body)

0.589049	0.0	0.0	0.0	0.0	0.0	0.0	0.0
0.0	0.589049	0.0	0.0	0.0	0.0	0.0	0.0
0.0	0.0	0.589049	0.0	0.0	0.0	0.0	0.0
0.0	0.0	0.0	0.589	0.0	0.0	0.0	0.0
0.0	0.0	0.0	0.0	0.589	0.0	0.0	0.0
0.0	0.0	0.0	0.0	0.0	0.589	0.0	0.0
0.0	0.0	0.0	0.0	0.0	0.0	0.0	0.0
0.0	0.0	0.0	0.0	0.0	0.0	0.0	0.0

1 idamp

0.0	0.0	0.0	0.0	0.0	0.0	0.0	0.0
0.0	0.0	0.0	0.0	0.0	0.0	0.0	0.0
0.0	0.0	0.4	0.0	0.0	0.0	0.0	0.0
0.0	0.0	0.0	0.0	0.0	0.0	0.0	0.0
0.0	0.0	0.0	0.0	0.0	0.0	0.0	0.0
0.0	0.0	0.0	0.0	0.0	0.0	0.0	0.0
0.0	0.0	0.0	0.0	0.0	0.0	0.0	0.0
0.0	0.0	0.0	0.0	0.0	0.0	0.1	0.0
0.0	0.0	0.0	0.0	0.0	0.0	0.0	0.0

0 istif

0

0

test17B.cfg:

ILOWHI=1

IPOTEN=0 (skip POTEN subprogram, use TEST17a.p2f)

IALTPOT=2

IALTFRC=2

ISOLVE=1

PANEL_SIZE = 0.2 (use default .spl parameters)

IPERIO = 3 (input wavenumber)

IRR=0

ILOG=1

NUMHDR=1

IGENMDS=17

USERID_PATH=\WAMITv6 (directory for *.exe, *.dll, and userid.wam)

A.18 ELASTIC COLUMN – TEST18

The same inputs are used as in the low-order test run TEST08, except for the GDF file. The circular column is represented by the subroutine CIRCCYL (IGDEF=-1). Since the cylinder is bottom-mounted, NPATCH=1 and the patch on the bottom of the cylinder is omitted. The draft is set equal to the fluid depth. IGENMDS=18 is assigned in CFG file, and in NEWMODES this results in a call to subroutine DEFINE for the four shifted Jacobi polynomials.

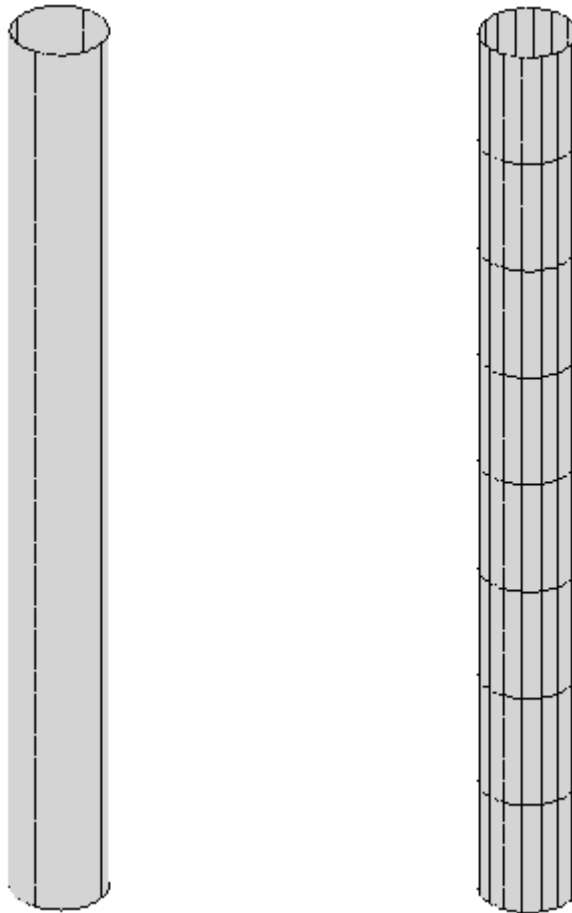

TEST18.GDF:

TEST18.GDF vertical cylinder, bottom mounted
1.0000 9.80665 ulen, grav
1 1 isx,isy
1 -1 npatch, igdef
2 nlines
10.0000 200.000 radius, draft
0 INONUMAP (uniform mapping)

TEST18.SPL:

TEST18.spl - bottom-mounted cylinder R=10 T=200 -- (npatch=1)
4 8 NU NV (Patch 1, side u azimuthal v vertical)

TEST18.POT:

TEST18.POT -- bending of vertical column at resonance, 200m depth
200.0 0.0 0.0 0.0 0.0
0 0 0
0 0
0 0 0 0 0 0
1
6.5
1
0.0

TEST18.FRC:

TEST08.FRC file, vertical column with 4 bending modes
1 1 1 1 0 0 0 0 0
1.0
.0000000 .0000000 1.000000
1
0. 0. 0. 0. 0. 0. 0. 0. 0. 0.
0. 0. 0. 0. 0. 0. 0. 0. 0. 0.
0. 0. 0. 0. 0. 0. 0. 0. 0. 0.
0. 0. 0. 0. 0. 0. 0. 0. 0. 0.
0. 0. 0. 0. 0. 0. 0. 0. 0. 0.
0. 0. 0. 0. 0. 0. 0. 0. 0. 0.
0. 0. 0. 0. 0. 0. 69115. 62832. 62832. 62832.
0. 0. 0. 0. 0. 0. 62832. 67320. 62832. 62832.
0. 0. 0. 0. 0. 0. 62832. 62832. 66323. 62832.
0. 0. 0. 0. 0. 0. 62832. 62832. 62832. 65688.
0
1
0. 0. 0. 0. 0. 0. 0. 0. 0. 0.
0. 0. 0. 0. 0. 0. 0. 0. 0. 0.

0.	0.	0.	0.	0.	0.	0.	0.	0.	0.
0.	0.	0.	0.	0.	0.	0.	0.	0.	0.
0.	0.	0.	0.	0.	0.	0.	0.	0.	0.
0.	0.	0.	0.	0.	0.	0.	0.	0.	0.
0.	0.	0.	0.	0.	0.	103044.	412177.	824354.	1339575.
0.	0.	0.	0.	0.	0.	412177.	4430902.	9789203.	16487078.
0.	0.	0.	0.	0.	0.	824354.	9789203.	37899671.	64382041.
0.	0.	0.	0.	0.	0.	1339575.	16487078.	64382041.	162406554.
0									
0									

test18.cfg:

MAXSCR=1024

ISOLVE=1

NUMHDR=1

NUMNAM=0

ISOR=0

IRR=0

NEWMDS=4

ILOWHI=1

IALTPOT=1

IALTFRFC=2

KSPLIN=3

IQUADO=3

IQUADI=4

IGENMDS=18

USERID_PATH=\WAMITv6 (directory for *.exe, *.dll, and userid.wam)

A.19 CATAMARAN BARGE – TEST19

The geometrical configuration is the same as the barge near a wall (TEST04). Since only head seas are considered, the hydrodynamic outputs correspond to TEST04 except for the different definition of the incident wave amplitude which applies for a body near a wall. In TEST19 IGDEF=0 is used, with four patches specified in the GDF file corresponding to one quadrant of the catamaran configuration. Since there are two hulls in this case, the forces acting on both hulls are two times the corresponding forces in TEST04, but since the incident wave amplitude in TEST04 is increased by a factor of two, the exciting force coefficients and RAO's are the same in both test runs, except for small differences in accuracy. Note that in TEST19 two planes of symmetry can be utilized, unlike TEST04 where reflection about the plane $x = 0$ is required by the program. The comparisons of cross-coupling coefficients and Haskind/Diffraction exciting forces implies that the results of TEST19 are more accurate, with less computational cost.

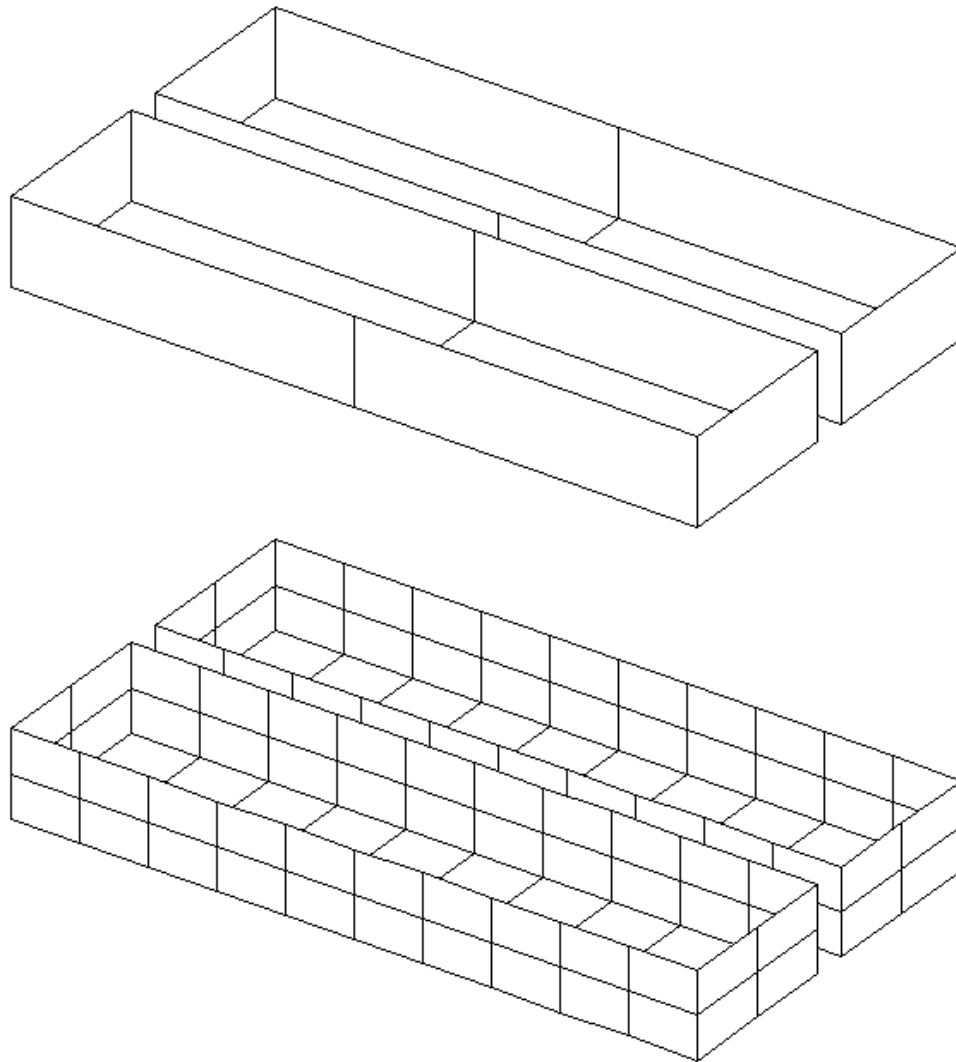

Generalized modes can be used to extend the analysis of this configuration to include two independent bodies. In this case each of the rigid-body modes of the catamaran must be supplemented by a corresponding generalized mode which has the same normal velocity on one barge, and the opposite phase on the other. The separate modes of each independent body are then evaluated by combining the corresponding symmetric and antisymmetric modes for the catamaran. It is simpler to use the option NBODY=2 for this purpose, but the number of unknowns is increased by a factor of four, resulting in a substantial increase of the run time. For the more efficient approach used in TEST19 it is necessary to represent the entire forward half of one barge, as shown in the patch figure. The subroutine BARGE (IGDEF=-5) is not suitable, since this only represents one quadrant of one barge. On the other hand, BARGE can be used in the alternative NBODY=2 approach.

TEST19.GDF:

TEST19 one quadrant of catamaran barge configuration

40. 9.80665 ULEN GRAV

1 1 ISX ISY

4 0 NPATCH IGDEF

40.0000	2.000000	-10.00000	
40.0000	22.00000	-10.00000	
40.0000	22.00000	0.000000	
40.0000	2.000000	0.000000	(end)
40.0000	22.00000	-10.00000	
0.000000	22.00000	-10.00000	
0.000000	22.00000	0.000000	
40.0000	22.00000	0.000000	(outside)
40.0000	2.000000	-10.00000	
0.000000	2.000000	-10.00000	
0.000000	22.00000	-10.00000	
40.0000	22.00000	-10.00000	(bottom)
40.0000	2.00000	0.000000	
0.000000	2.00000	0.000000	
0.000000	2.00000	-10.00000	
40.0000	2.00000	-10.00000	(inside)

TEST19.SPL:

TEST19 catamaran barge

2 2 NU NV (end)

4 4 KU KV

5 2 (outside)

4 4

5 2 (bottom)

4 4

5 2 (inside)

4 4

IQUO IQVO are not specified IQUADO=3 in config.wam

IQUI IQVI are not specified IQUADI=4 in config.wam

TEST19.POT:

TEST19.POT -- Catamaran barge, same geometry as TEST04

-1. 0. 0. 0. 0.

0 0 IQUAD,IDIAG must be read in IALTPOT, not used

0 1 IRAD,IDIFF

1 0 1 0 1 0

3

6. 7. 8.

1

0.0

TEST19.FRC:

TEST19.FRC -- Catamarn barge, ILOWHI=1 (same as TEST04.FRC)

1 1 1 1 0 0 0 0 1

3.0

20.00000 0.000000 0.000000

0.000000 5.000000 0.000000

0.000000 0.000000 20.00000

0

0

test19.cfg:

ipltdat=5

ILOWHI=1

IALTPOT=1

IALTFRC=1

IRR=0

ISOLVE=1

IQUADI=5

IQUADO=4

IPERIO=1

MONITR=0

NUMHDR=1

ILOG=0

isor=0 (must include since ialtpot=1)

USERID_PATH=\WAMITv6 (directory for *.exe, *.dll, and userid.wam)

A.20 MULTISURF BARGE – TEST20

This example illustrates the use of a MultiSurf geometry representation with IGDEF=2. The barge has a length of 100m, beam 20m, and draft 4.8m with one plane of symmetry ($y = 0$). The origin of the body coordinate system is at the intersection of the baseline and midship section. Thus XBODY=(0.0, 0.0, -4.8, 0.0) is input in the POT file. The format of the GDF file is as explained in Section 6.7 and Appendix 2. Four patches are used on one side of the body to represent the forebody, parallel middlebody, afterbody, and transom. Reference 24 includes results for a multiple-body configuration including two barge hulls identical to this model.

The body pressure is evaluated at the points specified in the input file test20.bpi, as explained in Section 4.11. The parameter IPNLBPT=1 in the .cfg file is used to specify this option with the input points specified in the body coordinate system.

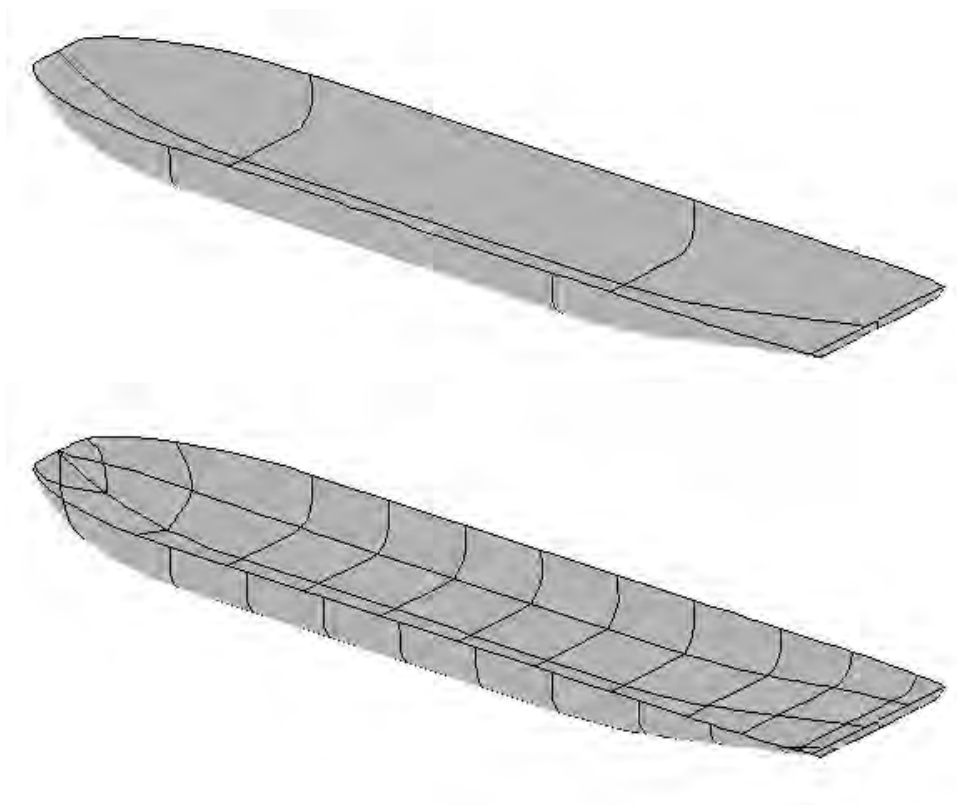

```

test20.pot:
single barge based on MultiSurf model (igdef=2)
-1.
  1      1          IRAD, IDIFF
  3          NPER (array PER follows)
  6.0 9.0 12.0
  3          NBETA (array BETA follows)
  180. 135. 90.
  1          NBODY
  test20.gdf
  0. 0. -4.8 0.0      XBODY
  1 1 1 1 1 1      IMODE(1-6)
  0          NEWMDS

```

```

test20.gdf:
Test run for barge modelled with MultiSurf
1.000000 9.806600 ULEN, GRAV
  0 1 ISX, ISY
  0 2 NPATCH, IGDEF
  3 NLINES
test20.ms2
wetted_surfs
0 0 0 FAST,DivMult, outward normals

```

```

test20.ms2: (lines 1-8 only)
MultiSurf 1.23
// Barge model for WAMIT
// J. S. Letcher, AeroHydro, Inc. 1/10/2002
Units: m MT
Symmetry: y
Extents: -50.000 -10.000 0.000 50.000 10.000 8.000
View: -30.00 60.00 0
Places: 3

```

```

test20.frc:
test20.frc igdef=2
  1 1 1 1 1 0 0 1 1      IOPTN(1-9)
  0.0          VCG
  10.00000    .0000000    .0000000
  .0000000    25.00000    .0000000
  .0000000    .0000000    25.00000    XPRDCT
  0          NBETAH
  0          NFIELD

```

test20.bpi: (lines 1-8 only)

bpi input file for test20, body pressure points for MultiSurf barge
556

-44.7760	0.0000	3.7926
-42.9236	0.0000	2.9037
-45.0675	0.2891	3.9523
-43.5608	0.6874	3.1868
-45.3541	0.5548	4.1152
-44.1782	1.2902	3.4831

test20.cfg:

MAXSCR=1024

ILOWHI=1

IALTFRC=1

IALTPOT=2

IRR=0

ISOLVE=1

NUMHDR=1

USERID_PATH=\WAMITv6 (directory for *.exe, *.dll, and userid.wam)

panel_size= 10.

IPNLBPT=1

A.21 SPAR WITH THREE STRAKES – TEST21

The subroutine SPAR (IGDEF=-12) is used to generate the SPAR with three strakes with the dimensions specified in TEST21.GDF. Except for the geometry, the inputs correspond to the low-order test runs TEST09.

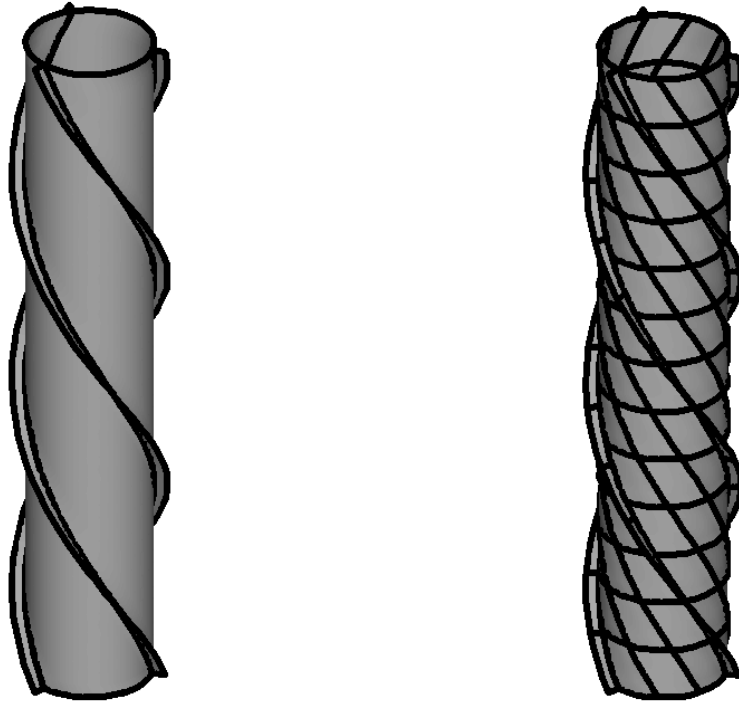

TEST21.GDF:

TEST21 SPAR2 with three strakes IGDEF=-12

18. 9.80665 ULEN GRAV

0 0 ISX ISY

7 -12 NPATCH IGDEF

npatch_dipole = 3

ipatch_dipole = 2 4 6

5

18. 200. RADIUS, DRAFT

3.7 0. 1. 3 WIDTH, THICKNESS, TWIST, NSTRAKE

0 IRRFRQ

0 0. IMOONPOOL, RADIUSMP

0 IMPGEN

TEST21.POT:

TEST21.POT SPAR with three strakes igdef=-12 (TEST21.GDF)

-1.

1 1 IRAD, IDIFF

3 NPER (array PER follows)

0.1 0.5 1.

2 NBETA (array BETA follows)

0. 120.

1 NBODY

test21.gdf

0. 0. 0. 0. XBODY

1 1 1 1 1 1 IMODE(1-6)

0 NEWMDS

TEST21.FRC:

TEST21.FRC SPAR with three strakes igdef=-12

1 1 1 1 0 1 1 2 0 IOPTN(1-9)

0.000000 VCG

100.000000 .0000000 .0000000

.0000000 100.000000 .0000000

.0000000 .0000000 10.000000 XPRDCT

0 NBETAH

2 NFIELD

23. 0. 0.

15. 15. -0.5 (end of file)

TEST21.CFG:

iplttdat=4

ilowgdf=4
ILOWHI=1
IALTPOT=2
IRR=0
ISOLVE=1
KSPLIN=3
IQUADO=3
IQUADI=4
IPERIO=3
MONITR=0
NUMHDR=1
NOOUT= 1 1 1 1 0 1 1 1 1
USERID_PATH=\WAMITv6 (directory for *.exe, *.dll, and userid.wam)
PANEL_SIZE=18
IPOTEN=1
ILOG=1

A.22 FPSO WITH TWO INTERNAL TANKS – TEST22

The subroutine FPSOINT (IGDEF=-21) is used to generate the FPSO with two internal tanks with the dimensions specified in TEST22.GDF. One plane of symmetry is specified, about $y = 0$. The tanks are rectangular, and the vertices of each patch are specified in TEST22.GDF. Both tanks have the same length (2m), breadth (4.2m), and depth (1.1m). The aft side of tank 1 and the forward side of tank 2 are in the same plane $x = 0.0$. The free surface of tank 1 is at $z = 1$, 1m above the plane of the exterior free surface. The free surface of tank 2 is at $z = 0.0$. The first and last patches of each tank are assigned by the parameter NPTANK. Both tanks contain fluid of relative density 1.0, as specified in TEST22.CFG. The parameter ITANKFPT=1 is used so that the field points can be assigned in each tank, on the last two lines of TEST22.FRC.

■ The option is used to evaluate the mean drift force and moment using a control surface, following the procedure described in Chapter 14. The parameter ICTRSURF=1 is assigned in the CFG file. The control surface surrounding the FPSO is automatic, defined by the input file TEST22.csf. The parameter PSZCSF is negative, indicating that the subdivision of the control surface is determined by the parameters in the file TEST22.CSP. A second CSF file is contained in the file `test22.csf` for illustration, but it is not read by the program unless it is moved to the top of the file. In the second case the outer boundary is circular, and PSZCSF is positive, indicating that automatic subdivision of the control surface is performed as described in Section 14.3.

The corresponding output for the mean drift force and moment is contained in the file TEST13.9c. Comparison of the results for the mean drift force in the sway direction from the files TEST22.9 (direct pressure integration) and TEST22.9c (control surface), with the far-field momentum drift force data in TEST22.8, confirms that the control surface gives a more accurate result compared to direct pressure integration for this body.

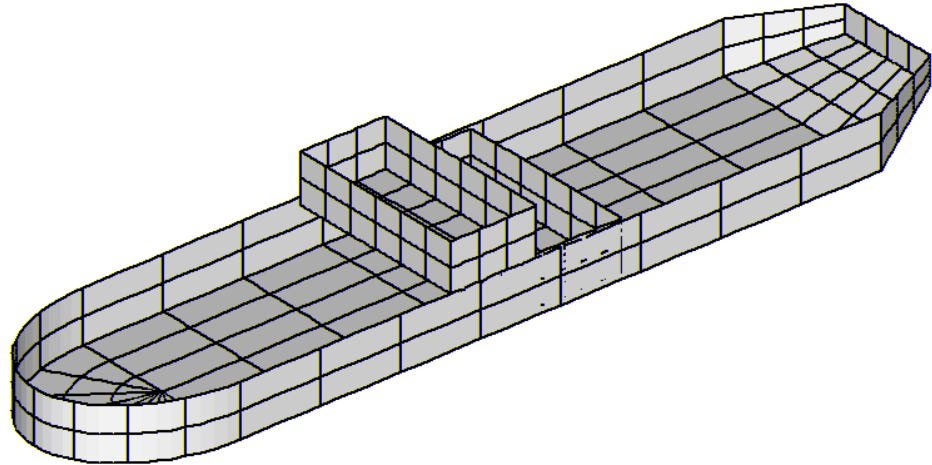
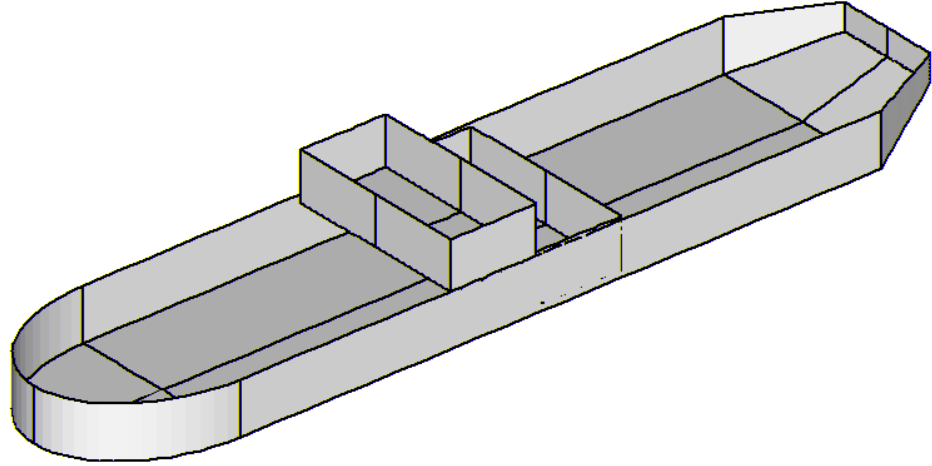

```

TEST22.GDF (complete file):
TEST22.GDF -- fpso with 2 tanks, one raised, joined at x=0
1. 9.80665  ULEN GRAV
0 1         ISX ISY
  15 -21    NPATCH IGDEF
36         NLines  4+16*2
3.  15.    2.    XBOW, XMID, XAFT
2.2  1.2   HBEAM, HTRANSOM
1.2  0.6   DRAFT, DTRANSOM
0 2       INONUMAP, NTANKS
  2.000000  0.0000000E+00  1.0000000E+00
  2.000000  2.100000    1.0000000E+00
  2.000000  2.100000    -0.100000
  2.000000  0.0000000E+00 -0.100000
  2.000000  2.100000    1.0000000E+00
  0.000000E+00  2.100000  1.0000000E+00
  
```

0.000000E+00	2.100000	-0.100000
2.000000	2.100000	-0.100000
0.000000E+00	0.000000E+00	-0.100000
2.000000	0.000000E+00	-0.100000
2.000000	2.100000	-0.100000
-0.000000E+00	2.100000	-0.100000
-0.000000	0.000000E+00	-0.100000
-0.000000	2.100000	-0.100000
-0.000000	2.100000	1.000000E+00
-0.000000	0.000000E+00	1.000000E+00
0.000000	0.000000E+00	0.000000E+00
0.000000	2.100000	0.000000E+00
0.000000	2.100000	-1.100000
0.000000	0.000000E+00	-1.100000
0.000000	2.100000	0.000000E+00
-2.000000E+00	2.100000	0.000000E+00
-2.000000E+00	2.100000	-1.100000
0.000000	2.100000	-1.100000
-2.000000E+00	0.000000E+00	-1.100000
0.000000	0.000000E+00	-1.100000
0.000000	2.100000	-1.100000
-2.000000E+00	2.100000	-1.100000
-2.000000	0.000000E+00	-1.100000
-2.000000	2.100000	-1.100000
-2.000000	2.100000	0.000000E+00
-2.000000	0.000000E+00	0.000000E+00

TEST22.POT:

TEST22.POT fpso with 2 interior tanks

-1.0

1 1 IRAD, IDIFF

3

2.0 2.5 3.0

1 NBETA (array BETA follows)

90.

1 NBODY

test22.gdf

0. 0. 0. 0. XBODY

1 1 1 1 1 1 IMODE(1-6)

0 NEWMDS

TEST22.SPL:

TEST22.SPL FPSO with two tanks

4 3
4 2
8 3
8 2
2 1
3 3
3 2
3 2
3 2
3 3
3 2
3 2
3 2
3 3
3 2

TEST22.FRC:

TEST22.FRC fpso with 2 tanks, one field point on free surface in each tank

1 1 1 1 0 1 1 1 1 IOPTN(1-9)
0.000000 VCG
1.000000 .0000000 .0000000
.0000000 1.000000 .0000000
.0000000 .0000000 1.000000 XPRDCT
0 NBETAH
2 NFIELD
1 1.0 1.0 1.0
2 -1.0 1.0 0.0

TEST22.CSF:

```
test22.csf FPS0, rectangular outer boundary
1 ILOWHICSF
0 1 ISX ISY
0 0 -2. NPATCH ICDEF PSZCSF (1st two indicate this is automatic)
0.0 2.0 RADIUS, DRAFT of outer box (0.0 signifies outer bdry defined below
1 NPART
4 nv0
12.0 0.0
12.0 3.0
-12.0 3.0
-12.0 0.0
```

THE FOLLOWING IS AN ALTERNATIVE CSF FILE WHICH IS NOT READ BY THE PROGRAM
UNLESS IT IS INTERCHANGED WITH THE FILE ABOVE.

```
test22.csf FPS0, circular outer boundary
1 ILOWHICSF
0 1 ISX ISY
0 0 2. NPATCH ICDEF PSZCSF (1st two indicate this is automatic)
12.0 2.0 RADIUS, DRAFT of outer box (0.0 signifies outer bdry defined below
0 NPART
```

TEST22.CSP:

```
Test22.CSP constrol surface spline file
1 1
1 1
1 6
1 1
1 1
2 1
12 1
2 1
2 12
```

```
TEST22.CFG:
ipltdat=4
ILOWHI=1
IALTPOT=2
IRR=0
ILOG=1
ISOLVE=1
KSPLIN=3
IQUADO=3
IQUADI=4
MONITR=0
NUMHDR=1
NOOUT= 0 0 0 0 0 0 0 0 0
USERID_PATH=\WAMITv6 (directory for *.exe, *.dll, and userid.wam)
NPTANK=(8-11) (12-15)
RHOTANK= 1.0 1.0 (relative densities of tank fluids)
ITANKFPT=1 (tank field points are in .frc file)
ICTRSURF=1 Evaluate control surface drift forces
```

- In test22a the waterline is trimmed with a roll angle of 15 degrees. In order to preserve the same mean depth of the vessel, the draft is increased by 1m in the GDF file, and a vertical trim $XTRIM(1)=1.0$ is specified in the CFG file. In this manner one ensures that the entire submerged portion of the hull surface is correctly defined. Since the draft is increased in the GFD file it is necessary to lower the tank bottoms by the same amount, thus the lower edges of the tank patches in test22a.gdf are 1m lower than in test22.gdf.

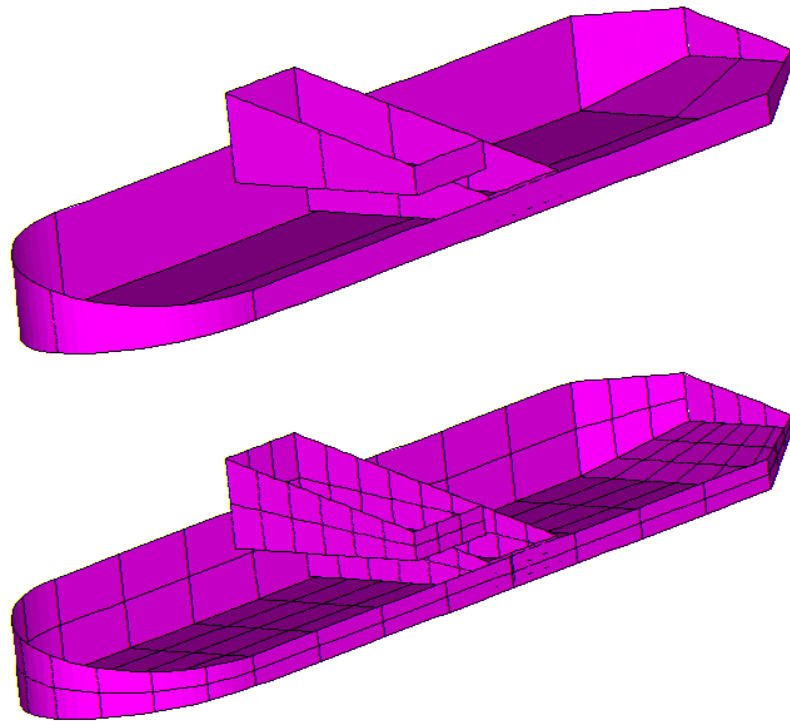

```

TEST22A.GDF (complete file):
TEST22a.GDF -- fpso with 2 tanks, trimmed waterline
1. 9.80665 ULEN GRAV
0 1      ISX ISY
  15 -21  NPATCH IGDEF
36      NLINES 4+16*2
3.  15.  2.      XBOW, XMID, XAFT
2.2  1.2  HBEAM, HTRANSOM
2.2  1.6  DRAFT, DTRANSOM
0 2      INONUMAP, NTANKS
  2.000000      0.0000000E+00  1.0000000E+00
  2.000000      2.100000      1.0000000E+00
  2.000000      2.100000      -1.100000
  2.000000      0.0000000E+00 -1.100000
  2.000000      2.100000      1.0000000E+00
  0.000000E+00  2.100000      1.0000000E+00
  0.000000E+00  2.100000      -1.100000
  2.000000      2.100000      -1.100000
  0.000000E+00  0.0000000E+00 -1.100000
  2.000000      0.0000000E+00 -1.100000
  2.000000      2.100000      -1.100000
 -0.000000E+00  2.100000      -1.100000
 -0.000000      0.0000000E+00 -1.100000
 -0.000000      2.100000      -1.100000
 -0.000000      2.100000      1.0000000E+00
 -0.000000      0.0000000E+00 1.0000000E+00
  0.000000      0.0000000E+00 0.0000000E+00
  0.000000      2.100000      0.0000000E+00
  0.000000      2.100000      -2.100000
  0.000000      0.0000000E+00 -2.100000
  0.000000      2.100000      0.0000000E+00
 -2.000000E+00  2.100000      0.0000000E+00
 -2.000000E+00  2.100000      -2.100000
  0.000000      2.100000      -2.100000
 -2.000000E+00  0.0000000E+00 -2.100000
  0.000000      0.0000000E+00 -2.100000
  0.000000      2.100000      -2.100000
 -2.000000E+00  2.100000      -2.100000
 -2.000000      0.0000000E+00 -2.100000
 -2.000000      2.100000      -2.100000
 -2.000000      2.100000      0.0000000E+00
 -2.000000      0.0000000E+00 0.0000000E+00

```

TEST22A.POT:

TEST22a.POT fpso with 2 interior tanks, trimmed waterline

-1.0

1 1 IRAD, IDIFF

3

2.0 2.5 3.0

1 NBETA (array BETA follows)

90.

1 NBODY

test22a.gdf

0. 0. 0. 0. XBODY

1 1 1 1 1 1 IMODE(1-6)

0 NEWMDS

TEST22a.CFG:

ipltdat=4

ILOWHI=1

IALTPOT=2

IRR=0

ILOG=1

ISOLVE=1

KSPLIN=3

IQUADO=3

IQUADI=4

MONITR=0

NUMHDR=1

NOOUT= 1 1 1 1 0 1 1 1 1

USERID_PATH=\WAMITv6 (directory for *.exe, *.dll, and userid.wam)

NPTANK=(8-11) (12-15)

RHOTANK= 1.0 1.0 (relative densities of tank fluids)

ITANKFPT=1 (tank field points are in .frc file)

ztankFS= 1.0 0.0

ITRIMWL=1

XTRIM=1.0 0. 15.0

A.23 RADIATED WAVE FIELD FROM A BANK OF WAVE-MAKERS – TEST23

Several variants are considered to illustrate the analysis of wavemakers in a wave tank.

In TEST23, following the procedure in Section 10.9, the option ISOLVE=-1 is used to compute the radiated waves from a bank of ‘paddle’ wavemakers. The wavemakers are in the plane $x = 0$ of a rectangular tank, as shown below. The tank has a reflecting wall at $y = 0$. The tank depth is 4m. Each wavemaker is represented by one rectangular patch, using IGDEF=0, with the vertices listed in TEST23.GDF. The motion of each wavemaker is rotational about its lower edge, at the same depth below the free surface, represented by a generalized mode with the same distribution of normal velocity and with symmetry prescribed about the walls $x = 0$ and $y = 0$. These generalized modes are defined in the subroutine WAVEMAKER, in the DLL file NEWMODES.F, designated by the parameter IGENMDS=21 in TEST23.CFG. This subroutine reads the depth of the lower edge of the wavemaker, ZHINGE=-2m, from the file WAVEMAKER_DEPTH.DAT. Wave elevations are evaluated at a square array of 64 field points defined in TEST23.FRC, using the uniform field point array option in Section 3.10.

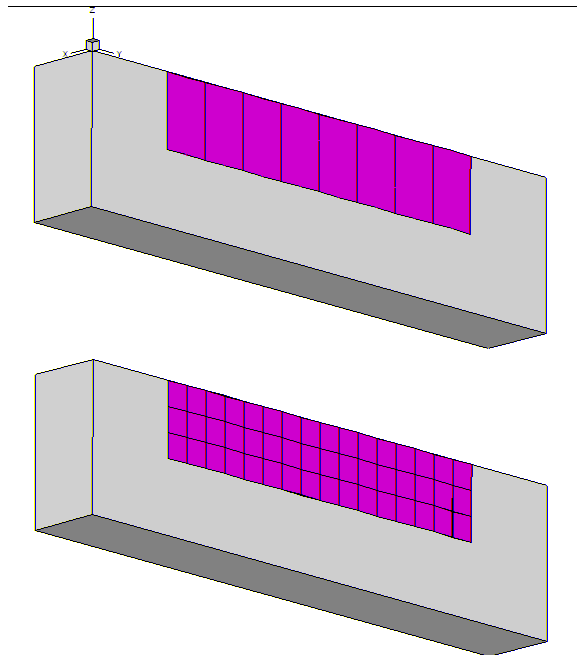

```

test23.cfg:
  ILOWHI=1
  IALTPOT=2
  IALTFRC=2
  IRR=0
  ISOLVE=-1          (skip POTEN solutions for wavemakers in walls)
  MONITR=0
  NUMHDR=1
  USERID_PATH=\WAMITv6 (directory for *.exe, *.dll, and userid.wam)
  IGENMDS=21         (use NEWMODES subroutine WAVEMAKER)
  PANEL_SIZE=1.      (use default .spl parameters)
  INUMOPT6=1         (output separate radiation modes in .6 file)
  IFIELD_ARRAYS=1   (field points input in array format in .frc file)

```

```

test23.pot:
TEST23.POT -- 8 wavemaker segments in wall x=0
  4. fluid depth
  0          -1          IRAD, IDIFF
  2          NPEN (array PER follows)
  2. 4.
  1          NBETA (array BETA follows)
  0.0
  1          NBODY

```

```

test23.gdf
  0. 0. 0. 0.          XBODY
  0 0 0 0 0 0          IMODE(1-6)
  8                    NEWMDS

```

```

test23.gdf:
TEST23.GDF wavemaker, 8 segments in wall x=0 2<y<10m, ISY=1
  1. 9.80665  ULEN GRAV
  1 1          ISX ISY
  8 0          NPATCH IGDEF
    0.0000    2.000000    -2.00000
    0.0000    3.00000    -2.00000
    0.0000    3.00000     0.00000
    0.0000    2.00000     0.00000    (end of Patch 1)
    0.0000    3.00000    -2.00000
    0.0000    4.00000    -2.00000
    0.0000    4.00000     0.00000
    0.0000    3.00000     0.00000    (end of Patch 2)
    0.0000    4.00000    -2.00000
    0.0000    5.00000    -2.00000

```

0.0000	5.00000	0.000000	
0.0000	4.000000	0.000000	(end of Patch 3)
0.0000	5.000000	-2.00000	
0.0000	6.00000	-2.00000	
0.0000	6.00000	0.000000	
0.0000	5.000000	0.000000	(end of Patch 4)
0.0000	6.000000	-2.00000	
0.0000	7.00000	-2.00000	
0.0000	7.00000	0.000000	
0.0000	6.000000	0.000000	(end of Patch 5)
0.0000	7.000000	-2.00000	
0.0000	8.00000	-2.00000	
0.0000	8.00000	0.000000	
0.0000	7.000000	0.000000	(end of Patch 6)
0.0000	8.000000	-2.00000	
0.0000	9.00000	-2.00000	
0.0000	9.00000	0.000000	
0.0000	8.000000	0.000000	(end of Patch 7)
0.0000	9.000000	-2.00000	
0.0000	10.00000	-2.00000	
0.0000	10.00000	0.000000	
0.0000	9.000000	0.000000	(end of Patch 8)

Special input file WAVEMAKER_DEPTH.DAT (used in NEWMODES):
WAVEMAKER_DEPTH.DAT for vertical coordinate of hinge of the wavemaker
-2.0 ZHINGE

test23.frc:

TEST23.FRC (field point wave elevations, IALTFRC=2, no external forces)

0	0	0	0	0	1	0	0	0	(IOPTN(1-9))
1.									(RHO -- fluid density)
0.	0.	0.							(XCG)
0									(IMASS)
0									(IDAMP)
0									(ISTIF)
0									(NBETAH)
0									(NFIELD -- no individual field points)
1									(NFIELD_ARRAYS -- number of arrays)
0									(Array is in exterior fluid domain)
8	2.5	1.0							(NFX, X1, DELX)
8	2.5	1.0							(NFY, Y1, DELY)
1	0.0	0.0							(NFZ, Z1, DELZ)

A.24 MOTIONS OF A HINGED VESSEL – TEST24

The subroutine CCYLHSP (IGDEF=-32) is used to generate a horizontal circular cylinder, with spheroidal ends, as shown below. The dimensions are specified in TEST24.GDF. Two planes of symmetry are specified. The cylinder is subdivided into five segments, to permit the analysis of a vessel with transverse hinges between the segments. Half of the middle segment and two others are in the domain $x > 0$. Four patches are required for these three elements plus the spheroidal end. The total number of segments, specified in TEST24.GDF, is used to read the x-coordinates of the boundaries between adjacent segments and also the end of the vessel. The total number of segments is equal to seven, including five cylinders plus two spheroids. Only the boundaries with coordinates $x > 0$ are included in the last line of the GDF file, since ISX=1.

The generalized modes which represent the deflection of the hinges are defined in the subroutine HINGE_MODES in the DLL file NEWMODES.F, designated by the parameter IGENMDS=22 in TEST24.CFG. This subroutine reads the appropriate input data from the file XHINGE.DAT, which is shown below. This input file also specifies the x-coordinates of the hinges. The last cylinder and the spheroidal end are considered to be rigidly joined. Thus there are five ‘active’ segments corresponding to the parameter NSEG in the XHINGE.DAT file, and NEWMDS=4 is assigned in the TEST24.POT file.

In the TEST24.FRC file, the 10×10 matrix of inertia coefficients is specified. No external damping or stiffness matrices are input, corresponding to the situation where the hinges are ideal without friction or other mechanical constraints.

Further information can be found in the headers and comments of the subroutines which are used to generate the geometry and to represent the hinge modes.

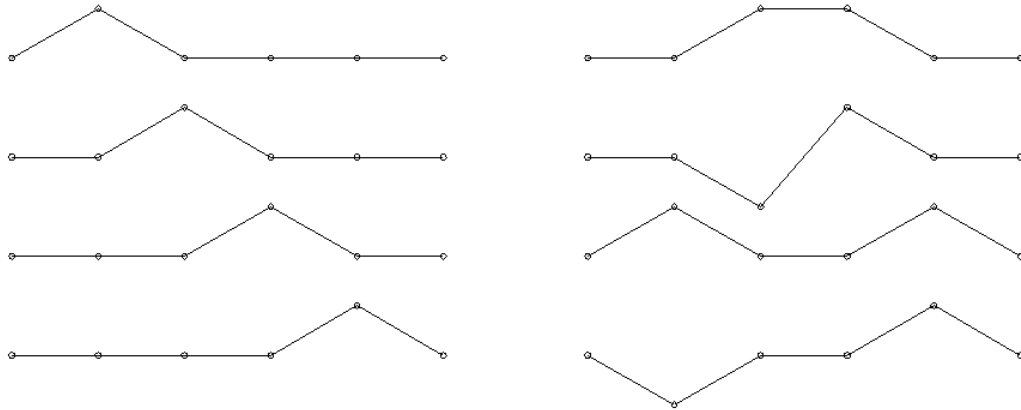
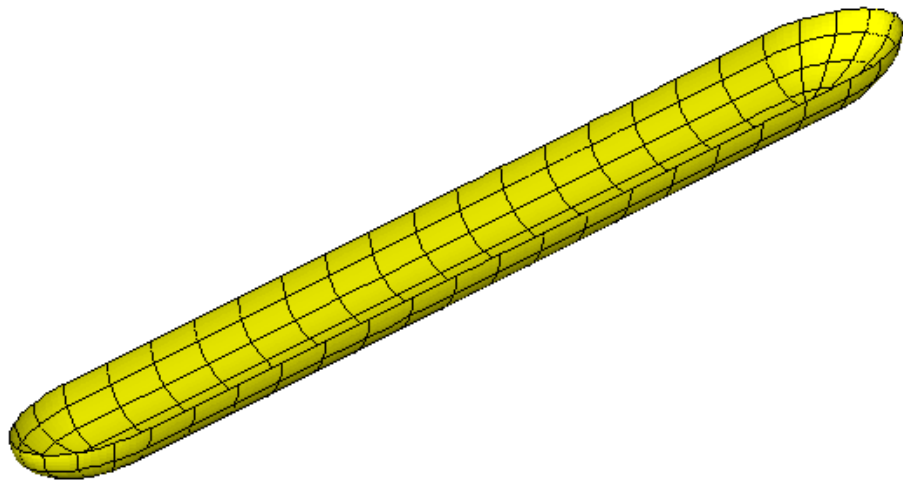
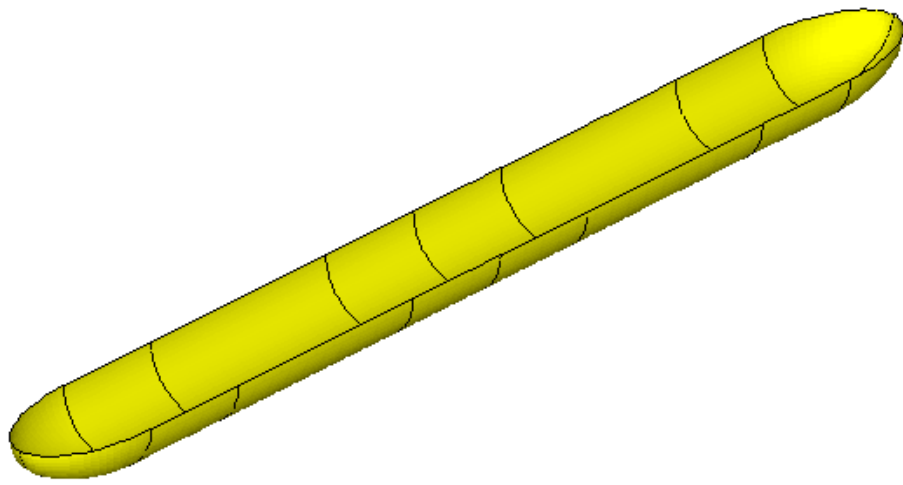

Figure A.1: Generalized modes used for the hinged barge with four hinges. The modes on the left are ‘tent functions’, suitable for use when ISX=0. When ISX=1 each mode must be either symmetric or antisymmetric, as shown in the right column. The latter modes are used for TEST24. The conventional rigid-body modes in heave and pitch represent the nonzero vertical motions at the two ends.



TEST24.GDF:

TEST24 segmented vessel with 7 segments

```
1. 9.80665 ULEN GRAV
1 1      ISX ISY
4 -32    NPATCH IGDEF
3      NLINES
7      Nsegments
1.      Radius
2. 6. 8. 10.  xseg
```

TEST24.SPL:

TEST24 elastic barge

TEST24 segmented vessel with 7 segments

```
4 2      NU NV   mid cylinder
4 4      next cylinder
4 2      outer cylinder
4 4      spheroidal end
```

TEST24.POT:

TEST24 segmented vessel with 7 segments and 4 hinge modes

```
-1.  
0          0          IRAD, IDIFF  
2          NPER (array PER follows)  
3. 5.  
1          NBETA (array BETA follows)  
180.  
1          NBODY  
test24.gdf  
0. 0. 0. 0.          XBODY  
1 0 1 0 1 0          IMODE(1-6)  
4          NEWMDS
```

XHINGE.DAT file for hinge coordinates of hinged body used in TEST24

```
1 5          ISX, NSEG  
2. 6. 10. XHINGE(0:NSEG)
```

TEST24.FRC:

TEST24 segmented vessel with 7 segments and 4 hinge modes

```
1 1 1 1 0 0 0 0 0  
1000.  
0. 0. 0.  
1  
29321.5    0.    0.    0.    0.    0.    0.    0.    0.    0.  
0.    29321.5    0.    0.    0.    0.    0.    0.    0.    0.  
0.    0.    29321.5    0.    0.    0.    12000.    0.    12000.    0.  
0.    0.    0.    1.5E4    0.    0.    0.    0.    0.    0.  
0.    0.    0.    0.    7.33E5    0.    0.    24000.    0.    72000.  
0.    0.    0.    0.    0.    7.33E5    0.    0.    0.    0.  
0.    0.    12000.    0.    0.    0.    10000.    0.    2000.    0.  
0.    0.    0.    0.    24000.    0.    0.    6000.    0.    2000.  
0.    0.    12000.    0.    0.    0.    2000.    0.    8000.    0.  
0.    0.    0.    0.    72000.    0.    0.    2000.    0.    8000.  
0  
0  
0  
0
```

TEST24.cfg:
ipltdat=5
ILOWHI=1
IALTPOT=2
IALTFRC=2
IRR=0
ILOG=0
ISOLVE=1
IQUADI=4
IQUADO=3
KSPLIN=3
IPERIO=1
MONITR=0
NUMHDR=1
IGENMDS=22
USERID_PATH=\WAMITv6 (directory for *.exe, *.dll, and userid.wam)